

ESTANISLAO PEDRO GREGORIO  
ECHEIQUE NUZARD  
LOS LIRIOS 356 RANLAGUA  
224762 5295469.1

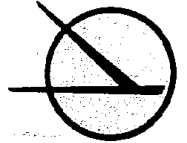

1956

# CESSNA 172

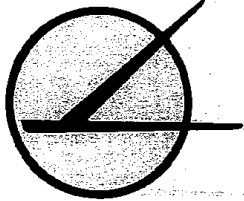
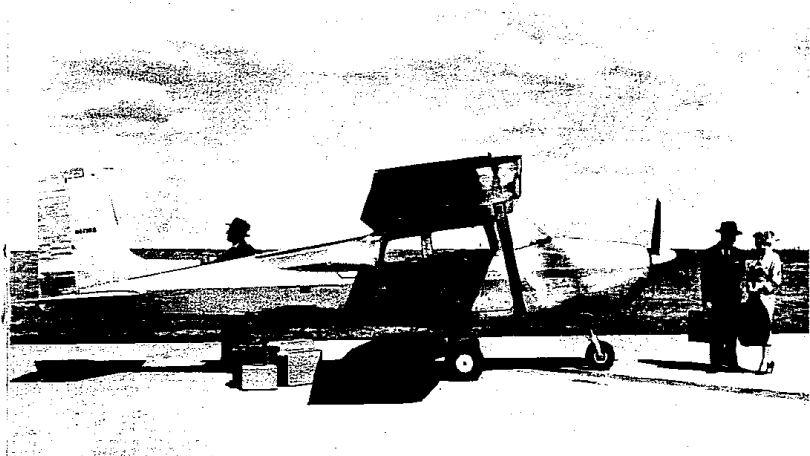

■ CESSNA AIRCRAFT COMPANY  
Wichita, Kansas ■

OWNER'S MANUAL

305 Kg máx.  
(pasajeros + equipaje)  
con estangues llenos

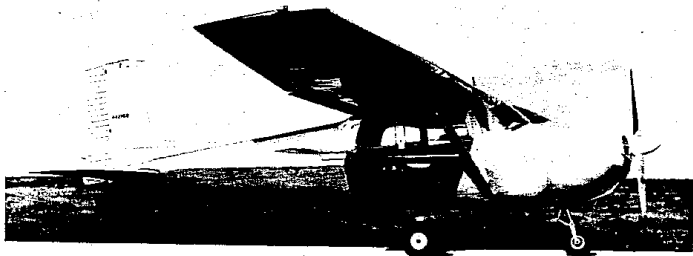

*"Your 172 Businessliner"*

P130A-13-RPC-200-5/83

## *Congratulations . . .*

- You are now the owner of a truly outstanding airplane. The Cessna 172 has been engineered to give you the ultimate in performance, styling, durability, flying comfort, and economy for both business and pleasure.
- We share your pride as a Cessna owner and have prepared this Owner's Manual as a guide to acquaint you with its fine construction, equipment, ease of operation and its care.
- Every fine possession is worth caring for, and this is especially true of your Cessna 172. This book is dedicated to help you operate your airplane to get the utmost flying enjoyment and service with a minimum of care.

29 NOV. 1984

T-897'962'9 T. R. T.

172

**PRINCIPLE  
DIMENSIONS**

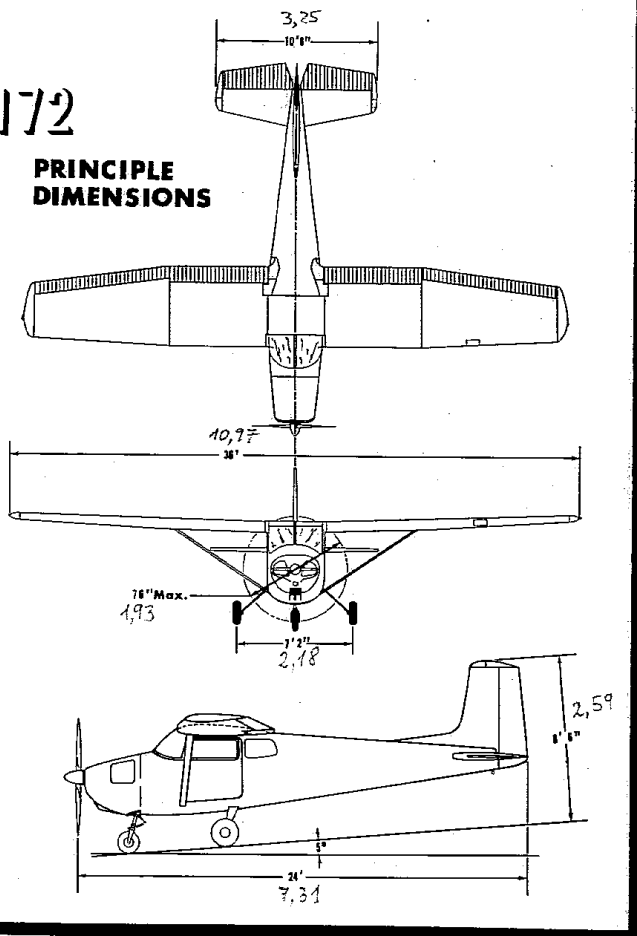

**TABLE OF CONTENTS**

SECTION I — DESCRIPTION .....	1
SECTION II — OPERATING CHECK LIST .....	23
SECTION III — OPERATING DETAILS .....	29
SECTION IV — OPERATING LIMITATIONS .....	35
SECTION V — OPERATIONAL DATA .....	39
SECTION VI — CARE OF THE AIRPLANE— OWNER'S RESPONSIBILITIES .....	45
CROSS COUNTRY SERVICE .....	63
OPTIONAL EQUIPMENT .....	67
ALPHABETICAL INDEX .....	69

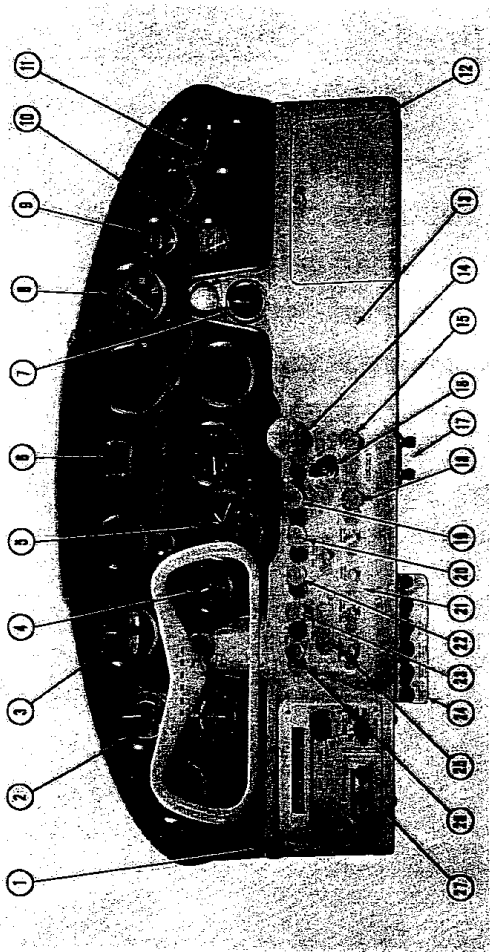

- 1. Headphone Jack
- 2. Airspeed Indicator
- 3. Turn and Bank Indicator (Optional Equipment)
- 4. Clock (Optional Equipment)
- 5. Altimeter
- 6. Magnetic Compass
- 7. Ammeter
- 8. Tachometer
- 9. Oil Pressure Gauge
- 10. Oil Temperature Gauge
- 11. Optional Instrument Space
- 12. Glove Compartment
- 13. Optional Radio Space
- 14. Throttle Primer
- 15. Engine Switch
- 16. Ignition Switch
- 17. Rheostat Switch
- 18. Cigarette Lighter
- 19. Carburetor Air Heat Control
- 20. Cabin Heat Control
- 21. Electrical Switch Panel (See figure 2)
- 22. Cabin Air Control
- 23. Mixture Control
- 24. Electrical Fuse Panel (See figure 3)
- 25. Parking Brake Control
- 26. Starter Knob
- 27. Optional Radio Space

Figure 1. Instrument Panel

## SECTION I

### description

ONE OF THE FIRST STEPS in obtaining the utmost performance, service, and flying enjoyment from your Cessna is to familiarize yourself with your airplane's equipment, systems, and controls. This section will tell you where each item is located, how it operates and its function.

### ENGINE.

The power plant used in your Cessna 172 is a six cylinder, 145 horsepower, Continental Model O-300-A engine. Continental's accumulated years of experience in the manufacture of light aircraft engines assure you of a precision made, skillfully engineered product. The built in Red Seal quality, which is now yours, is your guarantee of maximum safety, trouble-free operation, and low maintenance cost.

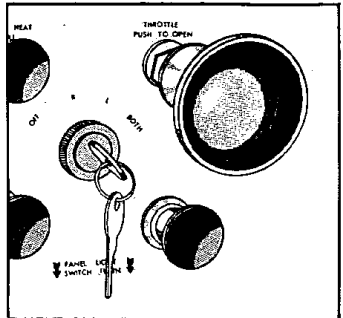

### ENGINE CONTROLS.

**Throttle.** The throttle (14, figure 1) is located slightly right of center on the stationary instrument panel and is easily identified by its large, round knob. Engine rpm can be increased by pushing the throttle in toward the instrument panel or decreased by pulling the control out.

throttle and counter-clockwise rotation decreases the friction.

**Mixture Control.** The mixture control (23, figure 1) is the fourth knob to the left of the throttle. A locking lever is incorporated on the control to prevent unintentional use of the mixture control. To lean the mixture, it is necessary to depress the locking lever while pulling the mixture control knob out. This operation can be accomplished with one hand by using the thumb to press the locking lever in and the index and middle fingers to pull the mixture control knob out. The locking lever is effective only in

### NOTE

To prevent "creepage" of the throttle, a knurled friction-type lock nut is incorporated on the control to secure it at any desired setting. Clockwise rotation of the nut increases the friction on the

## DESCRIPTION

the leaning operation. Forward movement of the mixture control is not affected by the locking lever.

The mixture control is normally set at "full rich" (all the way in) for start-

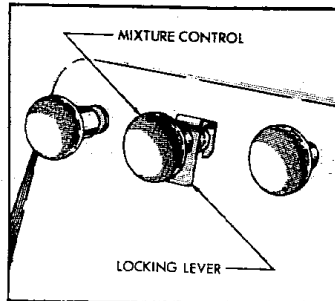

ing, take-off, and climb. Maximum performance take-offs from high elevation fields may be made with the mixture leaned out for maximum engine r.p.m. However, a full rich mixture is preferred for better engine cooling.

At any cruising altitude, adjust the mixture control for best rich power by pulling the mixture control out until maximum engine r.p.m. is obtained with fixed throttle; then, push the mixture control in toward "full rich" until r.p.m. begins to drop. Readjust mixture for each change in power, altitude, or carburetor heat.

**Carburetor Air Heat Control.** The carburetor air heat control (19, figure 1) is the first knob to the left of the throttle. The push-pull control operates the carburetor air intake butter-

fly valve, which proportions the hot and cold air entering the carburetor. Pulling the control out provides heated air for the carburetor while pushing the control all the way in provides only cold air for the carburetor.

Air pulled into the heater muffs and subsequently into the engine does not pass through the air filter. For this reason, when taxiing on dirty, dusty, or sandy fields, carburetor heat should not be used until the engine is cleared prior to take-off. After a full stop landing under these conditions, carburetor heat should be returned to full cold in order that the air filter becomes fully effective again.

Carburetor ice can form on the ground with the engine idling. Therefore, just before take-off, when you run the engine and test the magnetos, be sure to have the carburetor heat in the "on" position after the magneto check. Leave it in this position until just before you open the throttle for the take-off run. Then move carburetor heat to the "cold air" position. This gives maximum power for the take-off. Watch engine for any indications of ice (roughness or loss of r.p.m.) during climb and apply full carburetor heat if engine begins to ice.

The correct way to use carburetor heat is to first use full heat to remove any ice that is forming. By trial and error, determine the minimum amount of heat required to prevent the ice from forming; each time removing any ice that is formed by applying full heat. On each subsequent trial, increase the amount of heat applied

until no ice forms. On approach glide just before reducing power, apply full carburetor heat and leave in this position.

When full carburetor heat is applied, the engine will lose approx. 250-300 r.p.m. in cruising flight or 340 to 380 r.p.m. at full throttle. In addition to the r.p.m. loss, the engine will run rough due to too rich a mixture. Therefore, it is necessary to lean the engine whenever full carburetor heat is used.

Excessively lean fuel-air mixture will cause overheating and possibly detonation. *Do not lean the mixture unless an increase in engine r.p.m. results.*

**Ignition Switch.** The ignition switch (16, figure 1) is located a little below and to the left of the throttle. This switch is key operated and controls the dual magneto ignition systems. There are four switch positions designated clockwise as follows: "OFF", "R", "L", and "BOTH". The engine should be operated on both magnetos ("BOTH" position). The "R" and "L" positions are for checking purposes only.

**Engine Primer.** The engine primer (15, figure 1) is a manual plunger type and is located immediately below the throttle. *Ordinarily, the use of the primer is not required except at winter temperatures.* It is used to aid in starting the engine by supplying an initial charge of raw fuel to the cylinders.

To operate the primer, proceed as follows:

- (a) First, unlock the plunger by turning the knob counter clock-

## DESCRIPTION

wise until the knob pops part way out.

- (b) Slowly pull the plunger all the way out and then push the plunger all the way in. This action is termed "one stroke of the primer."
- (c) Normal winter weather will require two to four strokes of the primer, and very cold ( $-20^{\circ}$  F.) weather may require ten strokes.
- (d) Normally, the engine is started immediately after the priming operation. In very cold weather, it is recommended that the engine be turned over while priming. It may be necessary to continue priming until the engine runs smoothly.

**Starter Knob.** A starter knob (26, figure 1) is located to the left of the throttle adjacent to the left radio space. Pulling out on the control engages the engine starter. *Do not pull out on the starter knob when the propeller is turning.*

## ENGINE INDICATORS.

**Tachometer.** An engine recording tachometer (8, figure 1) is installed as standard equipment in your Cessna 172. This tachometer is mounted immediately above the space provided for the right control wheel shaft.

## OIL SYSTEM.

**Oil Level.** The oil capacity on the Continental O-300-A engine is eight quarts. The quantity can be checked easily by opening the access door on the left side of the engine cowl and

DESCRIPTION

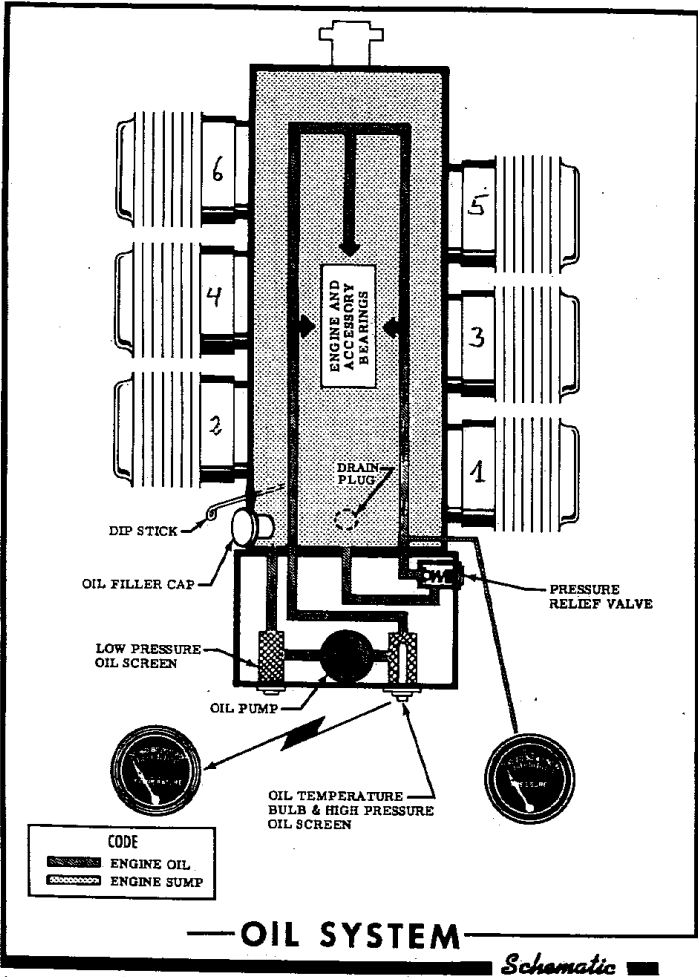

DESCRIPTION

reading the oil level on the dip stick located adjacent to the oil tank cap.



Oil System Indicators

**Oil Temperature Indicator.** A capillary type oil temperature gage (10, figure 1) is mounted to the right of the right control wheel shaft. The green arc defines the normal operating range of oil temperatures.

**Oil Pressure Gage.** An oil pressure gage (9, figure 1) is installed immediately above the oil temperature indicator. The gage is calibrated in pounds per square inch.

FUEL SYSTEM.

In replacing the dip stick, make sure that it is firmly back in place. In replacing the oil filler cap, make sure that it is on firmly and turned clockwise as far as it will go to prevent loss of oil thru the filler neck. While the minimum oil supply is four quarts, oil should be added if below six quarts and should be full if an extended flight is planned.

Fuel is supplied to the engine from two 21 gallon aluminum tanks, (of which 18.5 gallons in each tank are useable in all flight conditions) one located in each wing. From these tanks fuel flows by means of gravity through a fuel selector valve and fuel strainer to the engine carburetor.

Fuel Specification and Grade.

**Oil Specification and Grade.** Aviation grade oil is recommended for your Cessna 172 and should be changed every 25 hours of operation. When adding or changing oil, use the grades in the following table:

Aviation grade fuel should always be used except under emergency conditions. The recommended fuel is 80 octane rating minimum with a lead content of not more than 1/2 cc. per gallon. Highly leaded fuels are not recommended. Filling the fuel tanks immediately after flight will reduce the air space and minimize the moisture condensation in the fuel tanks.

Average Outside Temperature	Recommended Oil Grade
Below 50° F.	SAE 20
Above 50° F. 59°C to 40°C	SAE 40 (20)

Fuel System Controls.

**Fuel Selector Valve.** A rotary type fuel selector valve is located at the aft end of the cabin floor tunnel between the front seats. The valve has four positions labeled "BOTH OFF", "LEFT

DESCRIPTION

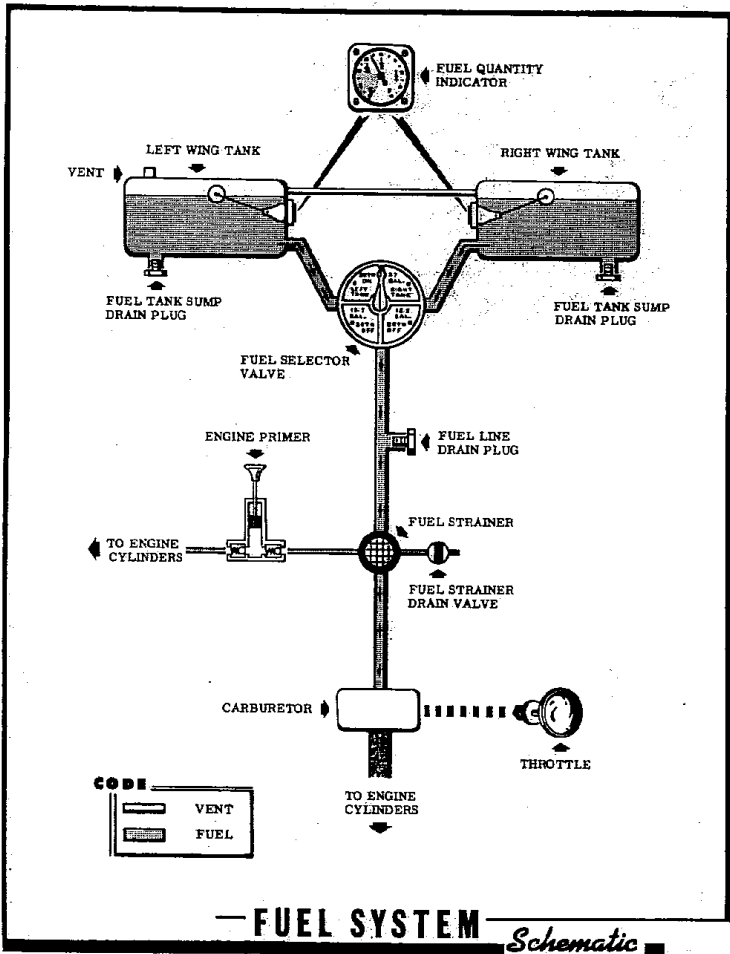

DESCRIPTION

TANK", "RIGHT TANK", and "BOTH ON". The "BOTH OFF" position seals both wing tanks off from the rest of the fuel system and allows no fuel to pass beyond the selector valve. The "LEFT TANK" position allows fuel to flow from the left wing tank to the engine. The "RIGHT TANK" position permits fuel to flow from the right wing tank to the engine. The "BOTH ON" position provides fuel flow from both tanks simultaneously to provide maxi-

might have collected in the fuel strainer. A one ounce quantity of fuel

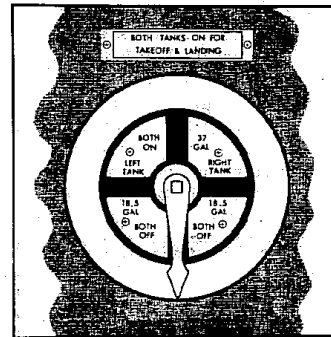
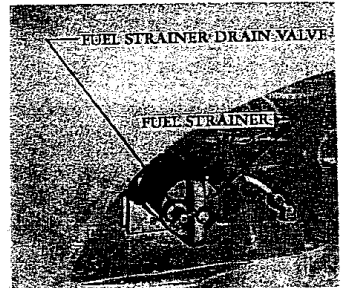

should be drained from the fuel strainer before the initial flight of the day or after each refueling operation.

**Fuel Tank Sump Drain Plugs.** A fuel tank drain plug is located on the underside of each wing in line with the rear edge of the cabin door and out a few inches from the fuselage. These plugs are used to drain any sediment or water that may collect in the fuel tanks. Draining the tank sumps is normally required only at each 100 hour inspection period.

mum safety. **Important** — The fuel valve handle indicates the setting of the valve by its positions above the valve dial.

**Fuel Line Drain Plug.** A fuel line drain plug is located on the under side of the airplane directly below the fuel tank selector valve. At each 100 hour inspection period, this plug should be removed to drain any sediment or water that might have accumulated in the fuel line.

**Fuel Strainer Drain Valve.** A fuel strainer drain valve is located on the bottom of the fuel strainer, and is accessible by reaching through the bottom rear opening of the engine cowl just forward of the firewall. This valve provides a quick simple method of draining any water or sediment that

**FUEL SYSTEM INDICATOR.**

**Fuel Quantity Indicators.** A direct-reading, dampened, float-type fuel

DESCRIPTION

quantity indicator is mounted in each tank at the wing root inside the cabin. Each gage indicates the amount of fuel remaining in its respective tank. A red arc is painted on the face of each indicator to warn the pilot that the respective fuel tank is almost empty.

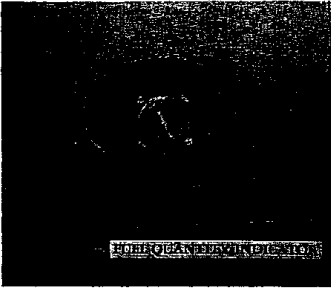

Do not take off if the pointer is in the red arc.

ELECTRICAL SYSTEM.

Electrical energy is supplied by a 12-volt, direct-current system powered by an engine-driven generator. A 12-volt storage battery serves as a stand-by power source, supplying current to the system when the generator is inoperative, or when the generator voltage is insufficient to close the reverse-current relay.

ELECTRICAL SYSTEM CONTROLS.

**Master Switch.** The master switch (6, figure 2) is the first knob to the left of the cigarette lighter. Switch positions are "ON" (out position) and "OFF" (in position). When the master switch is turned "ON", a solenoid switch is energized and the electrical power of the battery is admitted into the electrical system. In event of a short or malfunctioning of the airplane electrical system, the master switch may be turned off and the engine will con-

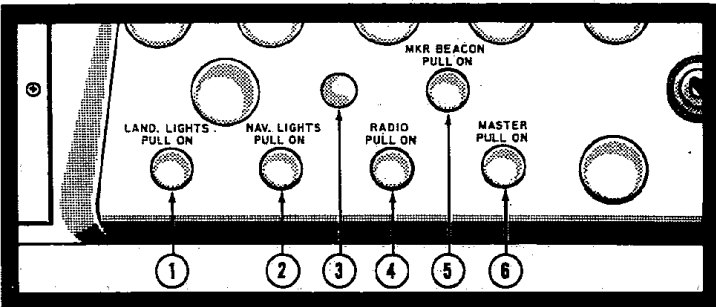
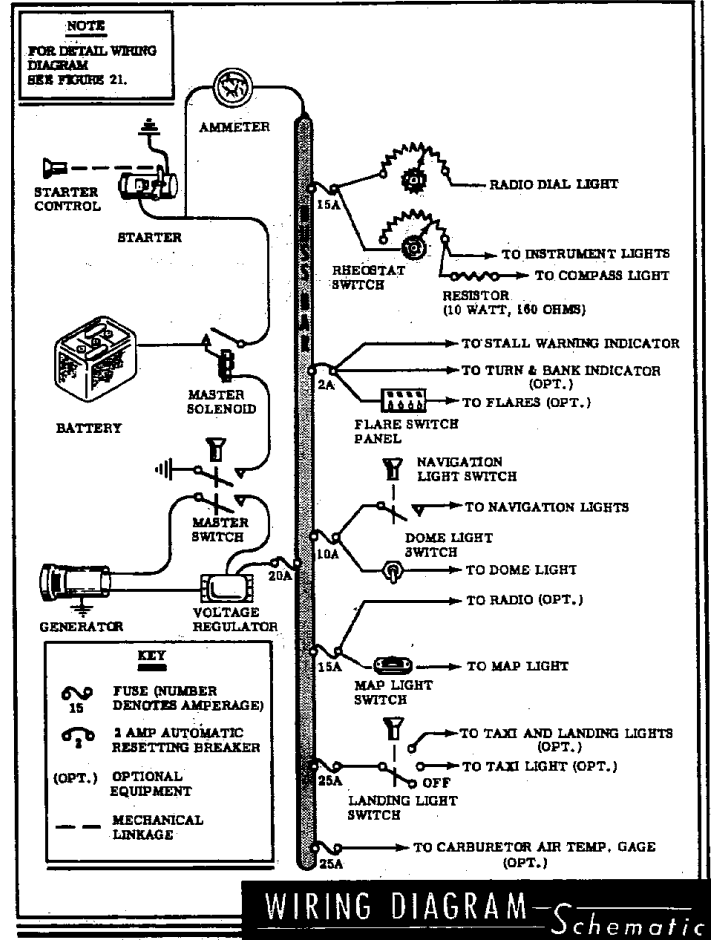

Figure 2. Electrical Switch Panel

- 1. Landing Light Switch      3. Cabin Heater Switch Space      5. Marker Beacon Switch Space
- 2. Navigation Light Switch      4. Radio Switch Space      6. Master Switch

DESCRIPTION



WIRING DIAGRAM - Schematic

**DESCRIPTION**

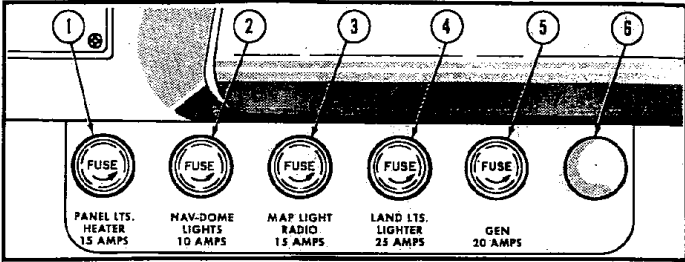

**Figure 3. Electrical Fuse Panel**

- 1. Panel Lights and Heater Fuse (15 amps)
- 2. Navigation and Dome Light Fuse (10 amps)
- 3. Map Light and Radio Fuse (15 amps)
- 4. Landing Light and Cig. Lighter Fuse (25 amps)
- 5. Generator Fuse (20 amps)
- 6. Spare Fuse Position

tinue to run on the magneto ignition system.

**Fuses.** Fuses for the various electrical devices are located beneath the electrical switches along the bottom edge of the instrument panel. The fuse circuit and fuse capacity are indicated below the respective fuse retainers. Fuses may be removed by unscrewing the fuse retainers and lifting out the fuse. Spare fuses are located in a clip on the inside of the glove compartment door. The turn and bank indicator and stall warning indicator are protected with an automatically resetting circuit breaker which provides intermittent emergency operation of these devices in case of a faulty circuit.

**ELECTRICAL SYSTEM INDICATOR.**

**Ammeter.** An ammeter (7, figure 1) is located just below the right control wheel shaft and indicates the generator charging rate. When the pointer is deflected to the "+" side of the

instrument, electrical energy is flowing into the battery from the generator; to the "-" side, more electrical energy is being used than is being replaced by the generator. The normal position of the pointer, when flying, is in the neighborhood of from 0 to +4 amps depending on how fully the battery is charged. Fluctuation of the pointer may be quite large in normal operation.

**FLIGHT CONTROL SYSTEM.**

Conventional wheel and rudder pedal controls are provided to operate the primary flight control surfaces (ailerons, rudder, and elevators). The elevator trim tab, located on the right elevator, is mechanically operated from the front seats. The rudder trim tab is adjustable on the ground only.

**FLIGHT CONTROL SYSTEM CONTROLS.**

**Control Wheels.** The elevator and aileron surfaces are operated by con-

**DESCRIPTION**

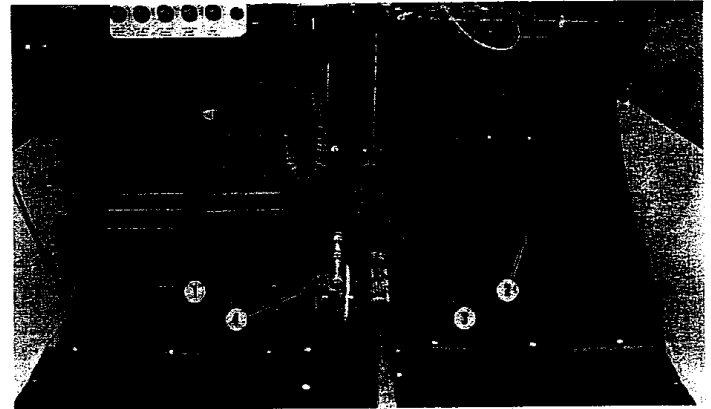

**Figure 4. Lower Forward Section Of Cabin**

- 1. Pilot's Rudder Pedals
- 2. Footrest
- 3. Wing Flap Handle
- 4. Elevator Tab Control Wheel

ventional movement of the control wheel. The control wheel is located directly in front of the pilot's seat and operates through the instrument panel. A dual control wheel is available as optional equipment.

**Rudder Pedals.** A set of rudder pedals (1, figure 4) are provided to operate the rudder. These rudder pedals are located just aft of the firewall directly in front of the pilot's seat. Dual rudder pedals are available as optional equipment.

**Elevator Tab Control Wheel.** The elevator trim tab is an auxiliary movable control surface located on the trailing edge of the right elevator. It is used to relieve control wheel pressures during flight. The tab is con-

trolled by rotating the tab control wheel (4, figure 4) which is located just ahead of and between the two front seats. A tab position indicator is incorporated in the tab wheel mechanism and indicates the nose attitude of the airplane. Forward movement of the wheel trims nose down and vice versa. This allows the airplane to be trimmed to fly level for a wide selection of load and speed conditions. Take-off is made with the tab position indicator set in "TAKE-OFF" position.

**Wing Flap Handle.** The wing flaps are controlled by a wing flap handle (3, figure 4) mounted between the two-front seats. The handle is operated by depressing the thumb button and moving the handle to the desired

flap setting. By releasing the thumb button, the handle can be locked to provide 0, 10, 20, 30, and 40-degree flap positions.

The flaps may be lowered or raised during normal flying whenever the airspeed is less than 100 m.p.h. The flaps supply added lift and considerable drag; the resulting action steepens the glide angle of the airplane, enabling the pilot to bring the airplane in over an obstruction and land shorter than could be done without flaps. The use of flaps is not recommended for cross-wind take-offs.

For unusually short field take-offs, apply 10° flaps (first notch) prior to take-off. An alternate procedure of applying 10° flaps just before the airplane is ready to leave the ground may be used in lieu of the above method of leaving the flaps in the 10° position throughout the entire ground run. For further discussion of the use of wing flaps for take-off, see page 31.

**Wing Flap Settings**

- For Normal take-off . . . . . Up (0°)
- For Shortest take-off . . . 1st notch (10°)
- For landing . . . . . 2nd notch (20°)
- 3rd notch (30°)
- 4th notch (40°)

**LANDING GEAR.**

**MAIN LANDING GEAR.**

Your airplane is equipped with Cessna's patented Safety Landing Gear. It consists of a tapered, spring steel leaf supporting each main wheel. This spring leaf replaces the complicated shock struts normally used in landing gears and is made from the

highest quality chrome-vanadium steel; heat-treated and shot-peened for added fatigue resistance. All this results in a trouble-free gear that never requires costly maintenance. It gives you wonderful comfort and handling ease—and practically paves the roughest fields.

**NOSE GEAR.**

A steerable nose gear, incorporating an air and oil shock strut, is mounted on the firewall. Nose wheel steering is accomplished through normal operation of the rudder pedals. The nose wheel is steerable through an arc of approximately 8° each side of neutral, after which it becomes free-swiveling up to a maximum deflection of 30° right or left of center. Thru the use of the brakes, the airplane can be pivoted about the outer wing strut fitting. The nose wheel is automatically located in the centered position while the aircraft is in the air. Movement of the rudder pedals will not affect the nose wheel while the airplane is in flight. Thus, the pilot has the assurance that the nose wheel will be straight at the initial landing touchdown.

**BRAKE SYSTEM.**

The hydraulic brakes on the main wheels are conventionally operated by applying toe pressure to either the pilot's or co-pilot's rudder pedals. The rotation of the pedals actuates the brake cylinders; resulting in a braking action on the main landing gear wheels. The brakes may also be set by operating the parking brake control.

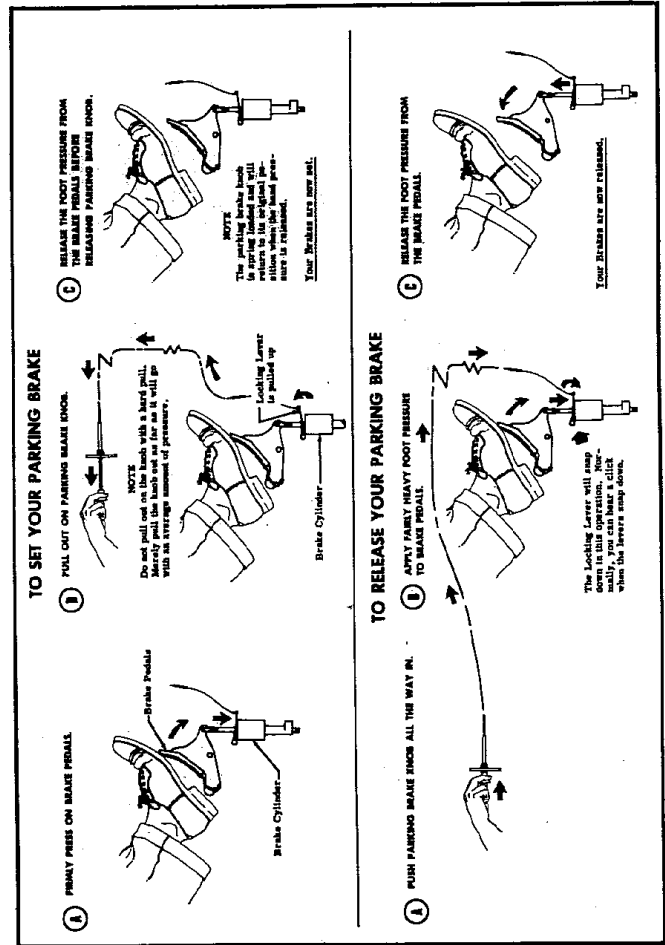

Figure 5. Parking Brake Operation

## DESCRIPTION

### BRAKE SYSTEM CONTROLS.

**Brake Pedals.** Conventional toe-type brake pedals are incorporated as the upper part of the pilot's and co-pilot's rudder pedals. Two brake cylinders are mounted directly to the pilot's brake pedals. Pressure applied to the co-pilot's brake pedals is transmitted by a mechanical linkage to the pilot's pedals which in turn actuate the brake cylinders.

**Parking Brake Control.** The parking brake control (25, figure 1) is operated in conjunction with the toe brake and is a part of the master brake cylinders. In setting the parking brake, *first* press the toe brakes to the desired brake pressure *then* gently pull the parking brake control out to engage the locking lever and release the toe brake pressure. *To release the brake,* push parking brake control in, apply pressure to the brake pedals, and then release them.

### INSTRUMENTS.

All instruments are mounted on the instrument panel with the exception of a free air temperature gage. The free air temperature gage (optional equipment) is located in the right cabin ventilator. For correct readings, the ventilator must be slightly open.

**Turn and Bank Indicator (Optional Equipment).** The turn and bank indicator, if installed as optional equipment, is an electrically operated instrument. Turned on by the operation of the master switch, the indicator remains in operation until the master switch is turned off. The indicator has no separate control switch.

**Pitot-Static System Indicators.** The airspeed indicator (2, figure 1) and altimeter (5, figure 1) are operated by



the pitot-static system. This system measures the difference between the impact air pressure entering the pitot tube, mounted on the leading edge of the left wing, and static air pressure obtained from a static port mounted on the left forward side of the fuselage. To keep the pitot tube opening clean, a cover may be placed over the pitot tube whenever the plane is idle

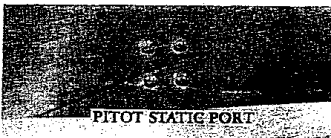

on the ground. *The static port should be kept free of polish, wax, or dirt for proper airspeed indicator operation.*

**Stall Warning Indicator.** A stall warning indicator is mounted on the back of the glove compartment box, next to the firewall. This instrument gives your 172 full and complete protection from inadvertent stalls. It gives warning whenever a stall is ap-

proached regardless of speed, attitude, altitude, acceleration or other factors which change the stalling speed. The stall warning horn is adjusted to give an audible warning approximately 5 mph above the normal straight ahead stalling speed. Other attitudes and speeds provide a wider margin.

The only time you may hear the Indicator under safe flight condition will be merely a short beep as you land. Usually no warning will be evident on a properly executed landing because the Indicator takes the ground effect into consideration. (If the airplane is leveled off high, however, the Indicator will signal.) The Indicator automatically cuts out on the ground, although high surface winds may give signals when taxiing. It therefore requires no silencing switch which might be inadvertently left off.

A manual is provided in the airplane kit which describes in detail the many useful purposes of this instrument.

**Clock (Optional Equipment).** An eight-day, stem wind, aircraft clock (4, figure 1) may be installed as optional equipment in the instrument mounting hole just to the right of the left control wheel shaft.

**Magnetic Compass.** A magnetic compass (6, figure 1) is located in the center and near the top of the instrument panel. The compass correction card is mounted directly below the compass for quick and easy reference when reading the magnetic headings.

### LIGHTING EQUIPMENT.

**Navigation Lights.** The navigation lights consist of a red light on the

left wing tip, a green light on the right wing tip, and a white light on the trailing edge of the rudder. The navigation light switch (2, figure 2) is mounted on the instrument panel. *To turn the navigation lights on,* pull the navigation light switch out. *To turn the lights off,* push the switch in.



**Landing Light.** (Optional Equipment). The landing light consists of two lamps mounted side-by-side in the leading edge of the left wing. One of the lamps is adjusted to give proper illumination of the runway during landing and take-off while the other lamp is set to provide illumination of the ground for taxiing purposes. The landing light switch (1, figure 2) is mounted on the instrument panel. *To turn the taxi light on,* pull the switch out to the first stop. *To turn both the landing light and the taxi light on,* pull the switch out to the second stop. *To turn lights off,* push the switch all the way in.

**Instrument Lights.** Two ultra-violet, fluorescent, instrument lights are mounted in the cabin ceiling. The lights, in conjunction with a compass light, are controlled by a rheostat switch (17, figure 1) located on the

## DESCRIPTION

**DESCRIPTION**

bottom edge of the instrument panel. To turn the compass and instrument lights on, rotate the instrument light rheostat switch clockwise until the desired illumination is obtained. To turn the lights off, turn the switch counter-clockwise as far as it will go.

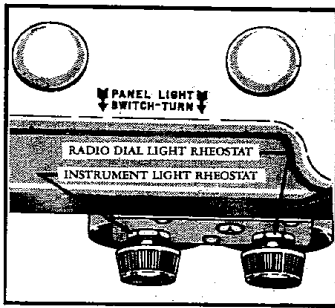

**Radio Dial Light.** A rheostat switch is provided as standard equipment to control your radio dial light or lights. The rheostat switch (17, figure 1) is located on the bottom edge of the instrument panel to the right of the instrument light rheostat switch. To turn the radio dial light on, rotate the radio dial light rheostat switch clockwise until the desired illumination is obtained. To turn the light off, turn the switch counter-clockwise as far as it will go.

**Map Light.** A map light is mounted adjacent to the left cabin ventilator and is controlled by a slide switch mounted on the left door post. The light is fully adjustable to shine in any direction, and a lens adjustment



knob integrally-mounted on the light makes it possible to change the beam from a spot to a flood illumination.

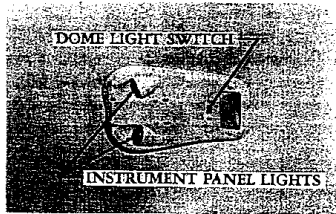

**Dome Light.** A dome light is mounted in the cabin ceiling and is controlled by a rogle switch mounted in the base of the dome light.

**CABIN VENTILATORS.**

All ventilation for the cabin area, excluding the ventilation obtained through heater ducts, is provided by manually-adjusted cabin ventilators. Two ventilators are installed; one on the left side of the cabin in the upper corner of the windshield, and

**DESCRIPTION**

tilator tube out. The amount of air entering the cabin can be regulated by varying the distance that the ventilator tube is extended.

To change the direction of air flow, rotate the ventilator tube to the position desired.

To stop the flow of air, push the ventilator tube all the way in.

**CABIN HEATER. MANIFOLD TYPE CABIN HEATER.**

A manifold-type cabin heater, incorporating windshield defrosting ducts, is standard equipment in your 172. The heater is operated by a cabin heater control (20, figure 1) which is the second knob to the left of the throttle. Pulling the control out per-

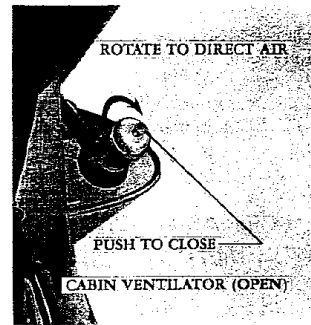

the other in the same position on the right side of the fuselage.

To provide a flow of air, pull ven-

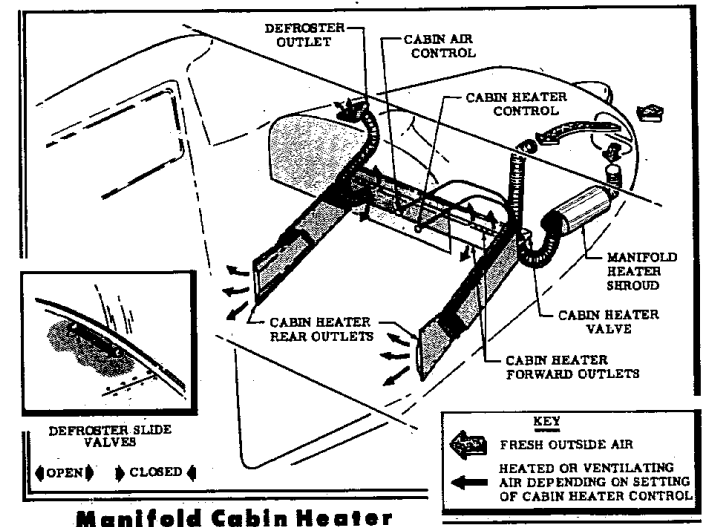

**Manifold Cabin Heater**

**DESCRIPTION**

mits heated, fresh air to enter the cabin through holes in each end of a duct running completely across the firewall. The rear cabin area is heated and ventilated by ducts, one on either side of the cabin, extending along each wall and terminating at the door posts.

A defroster opening just behind the windshield provides a flow of air to keep the windshield free of condensation and frost. The defroster outlet incorporates a slide valve to control the quantity of air passing through it.

The defrosting air will be hot or cool depending on the setting of the cabin heat knob.

To provide a flow of warm air, pull the cabin heater control out. To provide a flow of cool air, push the cabin heater control in.

To prevent any air (hot or cold) from entering the cabin through the heater ducts, push the cabin heater control in and pull the cabin air control out.

(Never pull the cabin air control out when the cabin heat control is out. This may result in overheating of the heater muff bosses.)

**SEATS.**

**FRONT SEATS.**

The front seats are individually mounted on tracks and are adjustable fore and aft. The seat adjustment handle is located within easy reach on the left front side of each front seat. To adjust the seat, simply pull up on the handle and slide the seat to the most comfortable position.

**REAR SEAT.**

The rear seat has provisions to accommodate two people. The back of the seat is hinged at the bottom to permit seat adjustment and easy access to the baggage compartment. A seat adjustment handle is located behind and at the top of the rear seat back.

**MISCELLANEOUS EQUIPMENT.**

**CABIN DOORS.**

Two cabin doors are provided on your Cessna 172. Each door incorporates a flush type door handle on the outside and a conventional type handle on the inside. To open the door

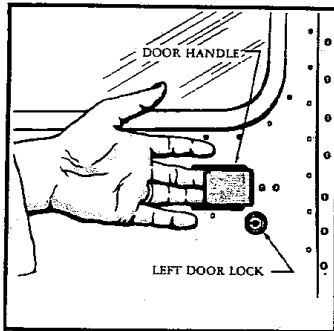

from the outside, pull out on the forward edge of the flush type handle. To open the door from the inside, rotate the inside door handle down.

The right cabin door can be locked from the inside only. To lock the door, push up on the thumb latch located on the aft part of the door just below

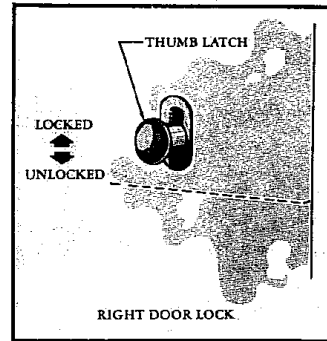

the window. To unlock, push down on the thumb latch.

The left door can be locked from the outside only with a key operated lock. The same key that is used for the ignition is also used to lock the door.

**CABIN WINDOWS.**

All windows in the cabin with the exception of the left door window,

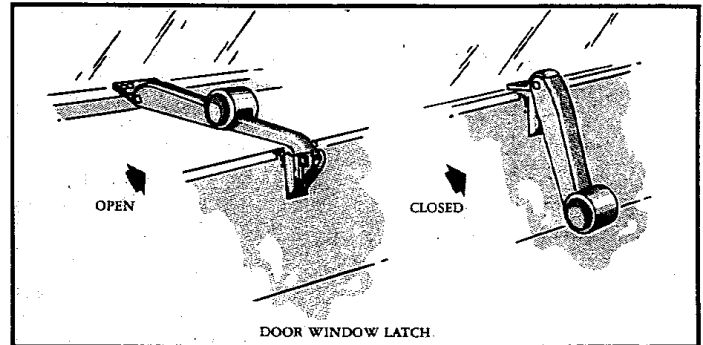

are of the fixed type and do not open. The window mounted in the left door is hinged along the top of the window and opens out and up. To open the door window, pull up and push out on the window latch. With the window latch completely extended, the window will remain open. To close the window, pull the window latch in and down.



**ASSIST HANDLES.**

One assist handle is installed in the deck above the instrument panel.

**DESCRIPTION**

This handle is very handy and is used to aid in adjusting the front seats and in entering and leaving the airplane.

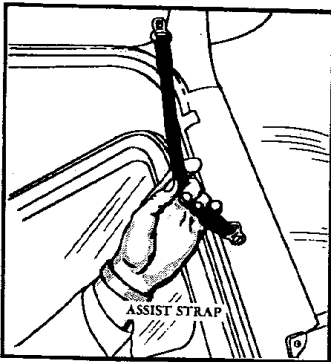

**ASSIST STRAPS.**

Two assist straps are mounted on the front door posts and are used as an aid in entering and leaving the airplane.

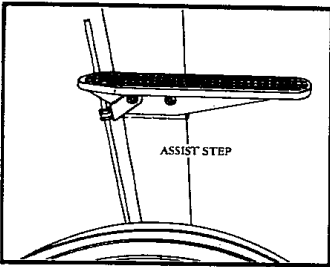

**ASSIST STEPS.**

An assist step is installed on each main landing gear spring to aid in entering and leaving the airplane.

**ASH RECEIVERS.**

Four ash receivers are provided in your Cessna 172. Two ash receivers



are located in the cabin walls adjacent to the windshield and are used by the occupants of the front seats. The re-



maining ash receivers are mounted on the cabin walls just aft of the rear door post bulkheads and are accessible to the rear seat passengers.

**CIGARETTE LIGHTER.**

A cigarette lighter (18, figure 1) is mounted on the instrument panel as standard equipment. Push the lighter all the way in to heat the element, and release. The lighter will automatically spring part way out when sufficiently heated. When replacing lighter in holder, press only part way in.

**DESCRIPTION**

**GLOVE COMPARTMENT.**

A glove compartment (12, figure 1) is located on the right side of the instrument panel. To open, pull out on glove compartment door knob.



**BAGGAGE COMPARTMENT.**

A baggage compartment is located just aft of the rear seat. To gain access to the baggage compartment, rotate the rear seat back, forward and down.

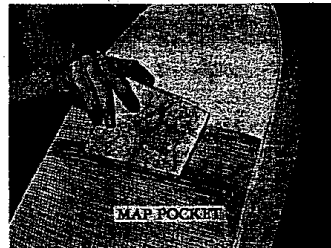

**MAP POCKETS.**

A map pocket is incorporated in the back of the right front seat. You

will find this pocket very handy for storing maps and flying aids.

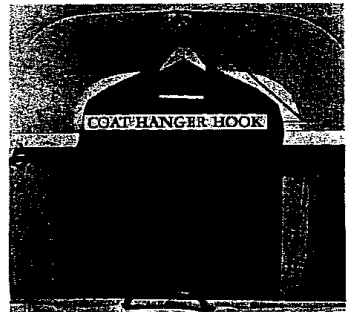

**COAT HANGER HOOK.**

For your convenience, a coat hanger hook has been installed in the cabin ceiling above the back of the rear seat. Your coats can be hung, full-length and wrinkle-free, between the back of the rear seat and the baggage shelf, without interfering with the comfort of rear-seat passengers.

**UTILITY SHELF.**

A utility shelf is located just above the baggage compartment. This shelf will prove very handy for storing hats, brief cases, and small articles.

**"LOADING YOUR MODEL 172"**

The recommended procedure for loading your Model 172 is as follows: *First*, load the baggage compartment. *Next*, load the front seats. *Finally*, load the rear seat.

**OPERATING CHECK LIST**

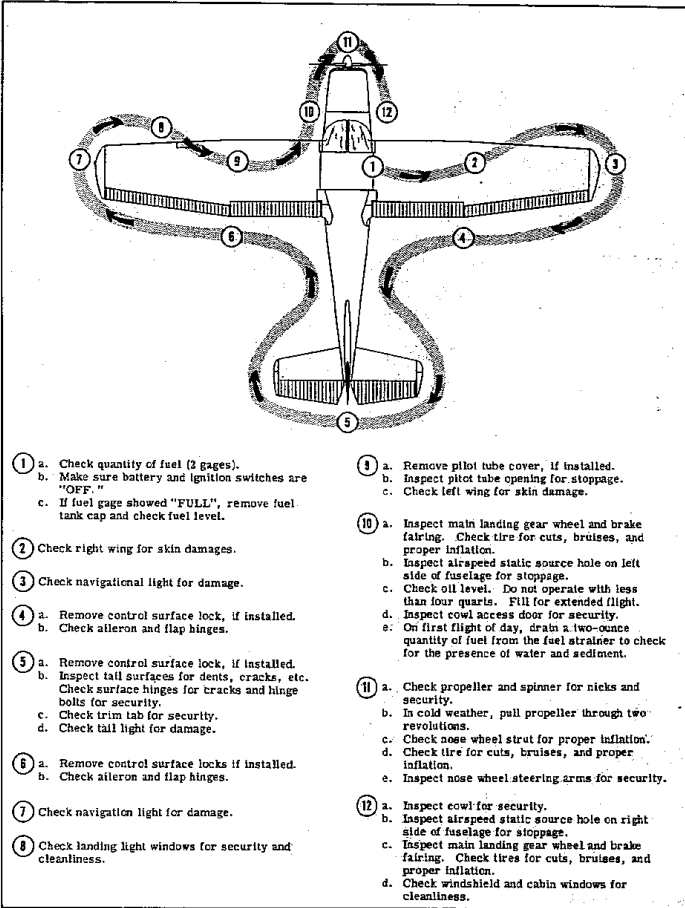

Figure 6. Exterior Inspection Diagram

**SECTION II**

**operating check list**

AFTER FAMILIARIZING YOURSELF with the equipment of your Cessna 172, your primary concern will normally be the operation of your airplane. This section lists, in Pilot's Check List form, the steps necessary to operate your Cessna efficiently and safely. It is not a check list in its true form as it is considerably longer, but it does cover briefly all of the points that you would want to or should know concerning the operation of your Cessna 172.

The flight and operational characteristics of the Model 172 Cessna are normal in all respects. There are no "unconventional" characteristics or operations that need to be mastered. All controls respond in the normal way within the entire range of operation of the airplane. All airspeeds mentioned in sections II and III are indicated airspeeds. Corresponding true indicated airspeeds may be obtained from the airspeed correction table in section V.

**A. BEFORE ENTERING THE AIRPLANE.**

- (1) Check oil level. Do not operate on less than four quarts. Fill for extended flights.
- (2) On first flight of the day, drain a small (one-ounce) quantity of fuel from fuel strainer drain to insure that no free water is in the line.
- (3) Check quantity of fuel.
- (4) Make a visual check of the airplane (see figure 6).
- (5) Remove control locks, and nose gear tow bar if installed.

**B. BEFORE STARTING THE ENGINE.**

- (1) Operate controls and make a visual check for proper operation.
- (2) Make sure windshield is clean for maximum visibility.
- (3) Adjust seat for comfort and distance to rudder pedals.
- (4) Check brakes and set parking brake.
- (5) Fasten and check safety belt.

**C. STARTING THE ENGINE.**

- (1) Set carburetor heat to "cold" (Full in).
- (2) Set mixture control to "full rich" (Full in).
- (3) Set fuel tank selector to "both tanks". (Take-off on less than 1/4 tank is not recommended.)

- (4) In normal weather temperatures use two to four strokes of the engine primer just before the engine starts.
- (5) Clear propeller.
- (6) Turn master switch "on".
- (7) Turn magneto switches "on".
- (8) Open throttle  $\frac{1}{8}$ " (to idle position).
- (9) Start engine by pulling starter control.

**D. WARM-UP AND GROUND TEST.**

- (1) Do not allow the engine to operate at more than 800 r.p.m. for the first 60 seconds after starting. After starting if oil gage does not begin to show pressure within 30 seconds in the summertime and about twice that long in very cold weather, stop engine and investigate. Lack of oil pressure may cause serious engine damage.
- (2) Avoid the use of carburetor heat unless icing conditions prevail.
- (3) After one to two minutes running at 800 r.p.m., continue warm-up while taxiing to the active runway. Do not overheat the engine by running engine at high speed while on the ground. When the engine accelerates smoothly and oil pressure remains steady, you are ready for take-off.

**NOTE**

To avoid propeller tip abrasion, do not run up engine on loose cinders or gravel.

**E. BEFORE TAKE-OFF.**

- (1) Apply toe brakes.
- (2) Set altimeter.
- (3) Set trim tab to "take-off" position.
- (4) Check oil pressure — should show 30 to 40 lbs./sq. in. (Minimum idling oil pressure — 10 lb./sq. in.).
- (5) Check engine magnetos at 1600 r.p.m. by switching off separately each magneto momentarily. The maximum allowable r.p.m. drop on either magneto is 100 r.p.m. Switch to both magnetos before continuing.
- (6) Check carburetor heat and leave on full heat until take-off.
- (7) Full throttle r.p.m. check is recommended only when condition of engine is in doubt. The engine should run smoothly and turn, with carburetor heat off, 2230 to 2330 r.p.m. The engine should idle between 400 and 500 r.p.m. Except for short check do not idle below 600 r.p.m.

**F. TAKE-OFF.****NORMAL TAKE-OFF.**

- (1) Flaps 0° (retracted).
- (2) Carburetor Heat — "OFF" (full in).
- (3) Advance throttle slowly to full throttle.
- (4) Avoid dragging brakes by keeping heels on floor.
- (5) Apply slight back pressure on the elevator control to raise nosewheel when take-off speed is reached.

**CAUTION**

Do not raise the nose of the airplane excessively high as this will only lengthen the take-off run.

- (6) Climb at 80 MPH.

**MINIMUM GROUND RUN TAKE-OFF.**

- (1) Wing flaps 10° (First notch).
- (2) Apply full throttle while holding brakes.
- (3) Release brakes.
- (4) Take-off slightly tail low.

**OBSTACLE CLEARANCE TAKE-OFF.**

- (1) Wing flaps 0° (retracted).
- (2) Apply full throttle while holding brakes.
- (3) Release brakes.
- (4) Take-off slightly tail low.
- (5) Level off momentarily to accelerate to best angle of climb speed (60 MPH).

**SOFT OR ROUGH FIELD TAKE-OFF WITH NO OBSTACLE AHEAD.**

- (1) Wing flaps 10° (First notch).
- (2) Apply full throttle and raise nosewheel clear of ground with elevator control back pressure.
- (3) Take-off in a tail low attitude.
- (4) Level off momentarily to accelerate to a safe airspeed.
- (5) Retract flaps slowly as soon as a reasonable altitude is obtained. (see "Take-off" paragraph on page 31).

**TAKE-OFF IN STRONG CROSSWIND.**

- (1) Flaps 0° (retracted).
- (2) Apply full throttle and use sufficient aileron into the wind to maintain

wings level.

- (3) Hold nosewheel on ground 5-10 MPH above normal take-off speed.
- (4) Take-off abruptly to prevent airplane from settling back to runway while drifting.

### G. CLIMB.

- (1) If no obstacle is ahead climb out with flaps up at 80-90 MPH with full throttle. If maximum rate of climb is desired use full throttle and 75 MPH, at sea level (See Figure 9). Reduce climb speed about ½ MPH for every 1000 feet of altitude above sea level.
- (2) To climb over an obstacle after take-off use the best Angle of climb speed of 60 MPH, with full throttle and flaps up.
- (3) Mixture should be "Full Rich" unless engine is rough due to rich mixture.

### H. CRUISING.

- (1) Recommended cruising r.p.m. — 2450.
- (2) Trim airplane by adjusting elevator tab.
- (3) Oil pressure — 30-40 lbs./sq. in.
- (4) Oil temperature — within green arc range.
- (5) Lean mixture to maximum r.p.m.; then enrichen mixture until r.p.m. begins to decrease.
- (6) Lean mixture as required to obtain smooth engine operation when using carburetor heat in cruise.

### I. LET-DOWN.

- (1) Set mixture control "Full Rich" (full in).
- (2) Reduce power to obtain desired let down rate at cruising speed.
- (3) Apply enough carburetor heat to prevent icing if icing conditions exist.

### J. BEFORE LANDING.

- (1) Set fuel selector to "Both".
- (2) Recheck mixture "Full Rich" (full in).
- (3) Apply carburetor heat before closing throttle.
- (4) Glide at 70-80 MPH, with flaps up.
- (5) Lower flaps as desired below 100 MPH.
- (6) Maintain 65-75 MPH, with flaps extended.
- (7) Trim airplane with elevator trim tab for glide.

### K. LANDING.

#### NORMAL LANDING.

- (1) Landing technique is conventional for all flap settings.

#### SHORT FIELD LANDING.

- (1) Make a power-off approach at 60 MPH, with flaps 40° (fourth notch).
- (2) Land on main wheels first.
- (3) Lower nosewheel to ground immediately after touchdown.
- (4) Apply heavy braking as required.

#### CAUTION

Excessive braking will skid tires, resulting in lengthened ground run and tire damage.

#### LANDING IN STRONG CROSSWIND.

- (1) Use minimum flap setting required for field length.
- (2) Use wing low, crab, or combination method of drift correction.
- (3) Land in a nearly level attitude.
- (4) Hold straight course with steerable nosewheel and occasional braking if necessary.

### L. AFTER LANDING.

- (1) Raise flaps after completion of landing roll.
- (2) Normal glide and taxiing should cool engine sufficiently; however, if excessive amount of taxiing is necessary, allow engine to cool before cutting ignition by allowing to idle at 800 r.p.m. two to three minutes.
- (3) Stop engine by pulling mixture control knob to full lean position. Do not open throttle as engine stops.
- (4) After engine stops, turn ignition switch "off".
- (5) Turn all switches "off". Be sure — otherwise your battery may run down over night.
- (6) Set parking brake, if required.

## MODIFIED FUEL MANAGEMENT PROCEDURES

With a combination of highly volatile fuel, high fuel temperature, high operating altitude, and low fuel flow rate in the tank outlet lines, there is a remote possibility of accumulating fuel vapor and encountering power irregularities on some airplanes. To minimize this possibility, the following operating procedures are recommended:

- (1) Take-off and climb to cruise altitude on "both" tanks.  
(This is consistent with current recommendations.)
- (2) When reaching cruise altitude above 5000 feet MSL, promptly switch the fuel selector valve from "both" tanks to either the "right" or "left" tank.
- (3) During cruise, use "left" and "right" tank as required.
- (4) Select "both" tanks for landing as currently recommended.

## POWER RECOVERY TECHNIQUES

In the remote event that vapor is present in sufficient amounts to cause a power irregularity, the following power recovery techniques should be followed:

### OPERATION ON A SINGLE TANK

Should power irregularities occur when operating on a single tank, power can be restored immediately by switching to the opposite tank. In addition, the vapor accumulation in the tank on which the power irregularity occurred will rapidly dissipate itself such that that tank will also be available for normal operation after it has been unused for approximately one (1) minute.

### OPERATION ON BOTH TANKS

Should power irregularities occur with the fuel selector on both tanks, the following steps are to be taken to restore power:

- (1) Switch to a single tank for a period of 60 seconds.
- (2) Then switch to the opposite tank and power will be restored.

## SECTION III

## operating details

THE FOLLOWING PARAGRAPHS cover in somewhat greater detail the items entered as a Check List in Section II. Every item in the list is not discussed here. Only those items on the Check List that required further explanation will be found in this section.

### CLEARING THE PROPELLER.

"Clearing" the propeller should become a habit with every pilot. Making sure no one is near the propeller before the engine is started should be a positive action. Yelling "clear" in loud tones is best. An answering "clear" from ground crew personnel is the response that is required.

### ENGINE OPERATING PROCEDURE.

You have a new Continental engine made to the highest standards available. This engine has been carefully operated in its run-in and flight tests so that the engine, as you receive it, is in the best possible condition. Proper engine operation will pay you rich dividends in increased engine life. The following points are mentioned so that you may receive the maximum of trouble-free operation and low maintenance cost.

1. **STARTING:** Ordinarily, the engine starts best and smoothly with proper priming and the throttle opened  $\frac{1}{8}$  inch. Check the oil pressure as soon as engine is running.
2. **WARM UP:** The engine should be warmed up at 800 to 1000

r.p.m. headed into the wind where possible. The remainder of the warm-up should be accomplished while taxiing and should not exceed 1600 r.p.m. Engine ground operation or idling in summer temperatures should be limited to the very minimum and, in most cases, starting, taxiing to the end of the runway, and checking the engine quickly is an adequate amount.

3. **TAKE-OFF:** Most engine harm results from improper operation before the engine is properly warmed and temperatures stabilized. For this reason, on your initial take-off, use maximum power only when and as necessary for safe operation of the airplane, reducing power as quickly as possible.
4. **CRUISING:** Any cruising r.p.m. between 2200-2450 (green arc on tachometer) may be selected. The recommended cruising r.p.m. is 2450, which will supply the most practical cruise performance when such factors as cruising speed, miles per gallon, fuel consumption, engine efficiency, and engine life are considered. At any cruising altitude, adjust mix-

ture control for best power by pulling knob out until maximum r.p.m. is obtained with fixed throttle; then push control forward toward "full rich" until r.p.m. starts to decrease. Readjust for each change in power, altitude, or carburetor heat.

5. **LET DOWN:** The cruising glide should begin far enough away from destination so that a gradual descent can be made with power on, with mixture full rich. On approaching the landing field, the engine should be throttled down gradually and the glide, with closed throttle, should not be longer than necessary.
6. **IDLING ENGINE:** Your engine is set to idle well below 600 r.p.m., but at engine speeds below 600 r.p.m., satisfactory piston lubrication cannot be maintained. Therefore, it is recommended that the engine not be allowed to operate below 600 r.p.m. for prolonged intervals.
7. **STOPPING ENGINE:** The engine should always be allowed to idle (600 to 800 r.p.m.) for two to three minutes before stopping. This not only permits the temperature of the various engine parts to equalize, but works oil up around the pistons and rings, thus leaving the engine in good condition for the next start. Providing the engine has been idled for approximately two minutes, it is recommended that the engine be stopped by using the

mixture control. The procedure should be to place the mixture control in full lean position (pull control out as far as possible). Do not open throttle as engine stops. After the engine stops, turn the ignition switch to the "off" position.

### TAXIING.

Release the parking brake before taxiing and use the minimum amount of power necessary to start the airplane moving. During taxi, the r.p.m. should be held down to prevent excessive taxi speeds that cause undue wear and strain on tires, brakes, and landing gear. Normal steering is accomplished by applying pressure to the rudder pedal in the direction the airplane is to be turned. For smaller radius turns, the brakes may be used on the inside wheel. This airplane may be pivoted about the outboard strut fitting without sliding the tires. Taxiing over loose gravel or cinders should be done at low engine speed to avoid abrasion and stone damage to the propeller tips. Full throttle run-ups over loose gravel are especially harmful to propeller tips.

### NOTE

Caution should be used when taxiing over rough fields to avoid excessive loads on the nosewheel. Rough use of brakes and power also add to the nose wheel load. A good rule of thumb: "On rough fields, use minimum speed, power, and brakes."

### TAKE-OFF.

Normal and obstacle clearance take-offs are performed with flaps retracted. The use of 10° flaps will shorten the ground run approximately 10%, but this advantage is lost in the climb to a 50 foot obstacle. However, if 10° of flaps are used in the ground runs, it is preferable to leave them extended rather than retract them in the climb to the obstacle. The exception to this rule would be in a high altitude take-off in hot weather where climb would be marginal with flaps 10°.

Flap deflections of 30° and 40° are not recommended at any time for take-off. General rules for flap operation during take-off are as follows:

*Don't* under marginal conditions leave flaps on long enough that you are losing both climb and airspeed.

*Don't* release flaps with airspeed below flaps up stalling speed. (See stalling speed table on page 32).

*Do* slowly release the flaps as soon as you reasonably can after take-off, preferably 50 feet or more over terrain or obstacles.

Consult take-off charts (Figures 8 and 9) for take-off distances under various gross weight, altitude, and headwind conditions.

### CLIMB.

For detailed data, see climb performance chart in Section V. Normal climbs are conducted at 80-90 m.p.h. with flaps up and full throttle for best engine cooling. The best *rate-of-climb*

speeds range from 75 m.p.h. at sea level to 70 m.p.h. at 10,000 feet. If an obstruction dictates the use of a steep climb angle, the best *angle-of-climb* speed should be used with flaps up and full throttle. These speeds vary from 56 m.p.h. at sea level to 63 m.p.h. at 10,000 feet.







### NOTE

Steep climbs at these low speeds should be of short duration because of poor engine cooling.

### CRUISE.

For cruise data, see cruise performance chart in Section V.

Range and endurance figures are given for lean mixture, from 2500 feet to 12,500 feet and for rich mixture at altitudes of 2,500 feet and 5,000 feet. All figures are based on zero wind, 37 gallons of fuel for cruise, McCauley 7651 propeller, 2200 pounds gross weight, and standard atmospheric conditions. For lean mixture figures, mixture is leaned to maximum r.p.m. Allowances for fuel reserve, headwinds, take-offs and climb, and variations in mixture leaning technique should be made and are in addition to those shown on the charts. Other indeterminate variables such as carburetor metering characteristics, engine and propeller conditions, and turbulence of the atmosphere may account for variations of 10% or more in maximum range.

<b>STALLING SPEEDS</b>					
<b>POWER OFF, MPH T.I.A.S.</b>					
<b>(IAS)</b>	<b>CONDITION</b>	<b>ANGLE OF BANK</b>			
		 <b>0°</b>	 <b>20°</b>	 <b>40°</b>	 <b>60°</b>
	<b>Flaps Up</b>	<b>58</b> (50)	<b>60</b>	<b>66</b>	<b>82</b> (80)
	<b>Flaps Down 10°</b>	<b>56</b>	<b>58</b>	<b>64</b>	<b>79</b>
	<b>Flaps Down 40°</b>	<b>52</b> (40)	<b>54</b>	<b>59</b>	<b>73</b> (70)

**STALLS.**

The stalling speeds shown above are for forward c.g., normal category, full gross weight conditions. Other loadings result in slower stalling speeds. The horn stall warning indicator produces a steady signal 5 to 10 m.p.h. before the actual stall is reached and remains on until the airplane flight attitude is changed. Fast landings will not produce a signal.

The stall characteristics are conventional for the flaps up and flaps down condition. Slight elevator buffeting may occur just before the stall with flaps down.

**LANDING.**

Normal landings are made power off with any flap setting. Slips are

prohibited in full flap approaches because of a downward pitch encountered under certain combinations of airspeed and sideslip angle.

Approach glides are normally made at 70-80 m.p.h. with flaps up, or 65-75 with flaps down, depending upon the turbulence of the air. The elevator trim tab is normally adjusted in the glide to relieve elevator control forces.

Landings are usually made on the main landing wheels to reduce the landing speed and the subsequent need for braking in the landing roll. The nose wheel is lowered gently to the runway after the speed is diminished to avoid unnecessary nose gear strain. This procedure is especially important in rough field landings.

Heavy braking in the landing roll

is not recommended because of the probability of skidding the main wheels with the resulting loss of braking effectiveness and damage to the tires.

**COLD WEATHER OPERATION.**

Prior to starting on cold mornings, it is advisable to pull the propeller through several times by hand to "break loose" or "limber" the oil, thus conserving battery energy. In extremely cold (-20° F) weather, prime the engine as follows:

- (1) Clear propeller.
- (2) Turn master switch "on".
- (3) With magneto switch "off" and throttle closed, prime the engine four to ten strokes as the engine is being turned over.
- (4) Turn magneto switches "on".
- (5) Open throttle 1/8 (to idle position) and start engine by pulling starter control. Note: In extremely cold weather a few strokes of the primer as the engine fires will enable the engine

to keep running. (Avoid over-priming.) After priming, push primer all the way in and turn to locked position to avoid possibility of engine drawing fuel through the primer. Do not pull out on starter for a second starting attempt until engine has come to a complete stop from the first attempt. Failure to do this may result in damage to the starting gear.

During cold weather operations, no indication will be apparent on the oil temperature gage prior to take-off if outside air temperatures are very cold. After a suitable warm-up period (2-5 Minutes at 1000 r.p.m.), accelerate the engine several times to higher engine r.p.m. If the engine accelerates smoothly and the oil pressure remains normal and steady, the airplane is ready for take-off.

For operation at temperatures consistently below freezing, a winterization kit consisting of plates for closing cowl openings is available at your distributor or dealer for a nominal charge.

## SECTION IV

### operating limitations

#### OPERATIONS AUTHORIZED.

Your Cessna 172 with standard equipment as certificated under CAA Type Certificate No. 3A12 is approved for day and night operation under VFR.

Additional optional equipment is available to increase its utility and to make it authorized for use under IFR day and night. When operated for hire at night, certificated flares are required. An owner of a properly equipped 172 is eligible to obtain approval for its operation on single engine scheduled airline service on VFR.

#### MANEUVERS — NORMAL CATEGORY.

The Model 172 exceeds the requirements of the Civil Air Regulations, Part 3, set forth by the United States Government for airworthiness. Spins and aerobatic maneuvers are not permitted in normal category airplanes in compliance with these regulations. In connection with the foregoing, the following gross weights and flight load factors apply:

Gross Weight .....	2200 lbs.	
Flight Load Factor* Flaps Up .....	+3.8	-1.52
Flight Load Factor* Flaps Down .....	+3.5	

\*The design load factors are 150% of the above and in all cases the structure meets or exceeds design loads.

Your airplane must be operated in accordance with all CAA approved markings, placards and check lists in the airplane. If there is any information in this section which contradicts the CAA approved markings, placards and check lists, it is to be disregarded.

#### MANEUVERS — UTILITY CATEGORY.

This airplane is not designed for purely aerobatic flight. However, in the acquisition of various certificates such as commercial pilot, instrument pilot and flight instructor, certain maneuvers are required by the C.A.A. All of these maneuvers are permitted in the Cessna 172 when operated in the utility category. In connection with the utility category, the following gross weight and flight load factors apply, with recommended entry speeds for maneuvers as shown.

Maximum Design Weight .....	1950 lbs.	
Flight Maneuvering Load Factor, Flaps Up .....	+4.4	-1.76
Flight Maneuvering Load Factor, Flaps Down .....	+3.5	

**OPERATING LIMITATIONS**

No acrobatic maneuvers are approved except those listed below:

Maneuver	Entry Speed
Chandelles	115 m. p. h. (100 knots)
Lazy Eights	115 m. p. h. (100 knots)
Steep Turns	115 m. p. h. (100 knots)
Spins	Slow Deceleration
Stalls (Except Whip Stalls)	Slow Deceleration

*The baggage compartment and rear seat must not be occupied.*

Aerobatics that may impose high inverted loads should not be attempted. The important thing to bear in mind in flight maneuvers is that the Cessna 172 is clean in aerodynamic design and will build up speed quickly with the nose down. Proper speed control is an essential requirement for execution of any maneuver and care should always be exercised to avoid excessive speed which in turn can impose excessive loads. In the execution of all maneuvers avoid abrupt use of controls.

**AIRSPED LIMITATIONS.**

The following are the certificated true indicated airspeed limits for the Cessna 172:

- Maximum (Glide or dive, smooth air).....160 mph (red line)
- Caution Range (Level flight or climb).....140-160 mph (yellow arc)
- Normal Range (Level flight or climb).....59-140 mph (green arc)
- Flap Operating Range.....55-100 mph (white arc)

**ENGINE OPERATION LIMITATIONS.**

- Power and Speed .....145 bhp at 2700 rpm

**ENGINE INSTRUMENT MARKINGS.**

**OIL TEMPERATURE GAGE.**

- Normal Operating Range .....Green Arc
- Maximum Allowable.....Red Line

**OIL PRESSURE GAGE.**

- Minimum Idling .....5 psi (red line)
- Normal Operating Range .....30-45 psi (green arc)
- Maximum .....50 psi (red line)

**OPERATING LIMITATIONS**

**TACHOMETER.**

- Normal Operation.....2200-2450 (green arc)
- Cautionary Range.....2450-2700
- Maximum Allowable.....2700 (red line)

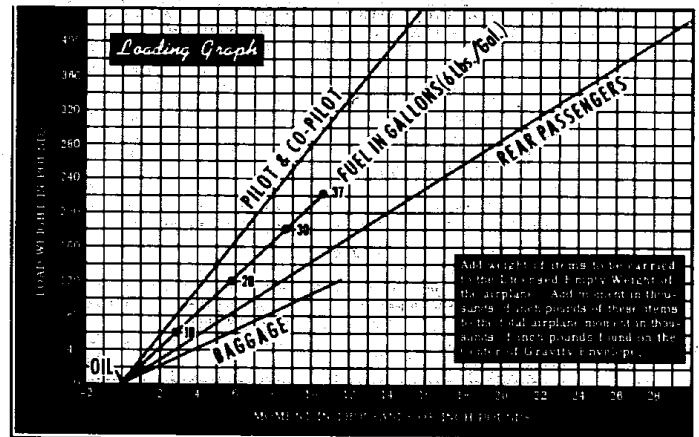
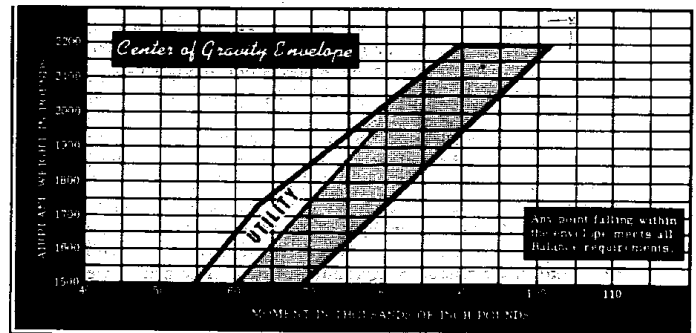

**WEIGHT AND BALANCE.**

All aircraft are designed for certain limit loads and balance conditions. These specifications for your 172 are charted on page 37.

A weight and balance report and equipment list for your particular airplane when it left the factory is furnished. Changes in original equipment affecting empty weight c. g. are required by the C.A.A. to be recorded in the repair and alteration form 337. Using the empty weight, c. g. location, and moment derived from the latest of these two sources, and following the example shown, the exact moment may be readily calculated. This exact moment, when plotted on the center of gravity envelope, will quickly show whether or not the c. g. is within limits. Refer to the loading graph for moment values of items to be carried.

The utility category is solely for the purpose of instructing and training in certain flight maneuvers. The weight and balance considerations limit the airplane to a pilot with or without co-pilot, full gas, no baggage and no rear seat baggage or passenger. The utility category envelope has been included in the weight and balance charts. The weight and moment of your airplane in the utility category may be determined by following the example shown for figuring a normal category airplane weight and moment. The utility weight and moment, when plotted on the center of gravity envelope, should fall within the "Utility" portion of the envelope for safe operation.

EXAMPLE FOR A NORMAL CATEGORY AIRPLANE WITH A LICENSED EMPTY WEIGHT OF 1290 LBS. AND A MOMENT OF 49,260 IN. LBS.

	WT.	MOMENT
		1000
EMPTY WEIGHT (LICENSED).....	585.0	1290 +49.3
OIL.....	15.8	15 - 0.3
PILOT & PASSENGER (1).....	150.2	340 +12.2
REAR PASSENGERS (2).....	130.5	290 +20.3
FUEL (MAXIMUM) 37 GAL.....	100.5	222 +10.7
BAGGAGE (TO MAKE GR. WT.).....	10.5	43 +4.1
Total.....	1081.5	2200 96.6

Locate this point (2200-96.8) on the center of gravity envelope graph, and, since the point falls within the envelope, the above loading meets all balance requirements.

**NOTE**

The above problem is an example of only one of many different loading configurations. To best utilize the available payload for your airplane, the loading charts on page 37 should be consulted to determine proper load distribution.

AVGAS = 6 pounds per gallon  
 OIL = 7.5 " " "

**SECTION V**

**operational data**

THE OPERATIONAL DATA shown on the following pages are compiled from actual tests with airplane and engine in good condition and using average piloting technique and best power mixture. You will find this data a valuable aid when planning your flights. However, inasmuch as the number of variables included precludes great accuracy, an ample fuel reserve should be provided. The range performance shown makes no allowance for wind, navigational error, pilot technique, warm-up, take-off, climb, etc. All of these factors must be considered when estimating reserve fuel.

To realize the maximum usefulness from your 172, take advantage of the high cruising speeds at 2450 rpm. However, if range is of primary importance, it may pay you to fly at a lower cruising rpm thereby increasing your range and allowing you to make the trip non-stop with ample fuel reserve. Use the range table on page 42 to solve flight planning problems of this nature.

In the table (Figure 10), range and endurance are given for lean mixture, from 2500 feet to 12,500 feet and for rich mixture at altitudes of 2,500 feet and 5,000 feet. All figures are based on zero wind, 37 gallons of fuel for cruise, McCauley 7651 propeller, 2200 pounds gross weight, and standard atmospheric conditions. For lean mixture figures, mixture is leaned to maximum r.p.m. Allowances for fuel reserve, headwinds, take-offs and climb, and variations in mixture leaning technique should be made and are in addition to those shown on the charts. Other indeterminate variables such as carburetor metering characteristics, engine and propeller conditions, and turbulence of the atmosphere may account for variations of 10% or more in maximum range.

AIRSPEED CORRECTION TABLE											
FLAPS UP OR DOWN											
IAS	40	50	60	70	80	90	100	110	120	130	140
TIAS	52	58	65	73	82	92	101	111	120	130	139

Figure 7. Airspeed Correction Table

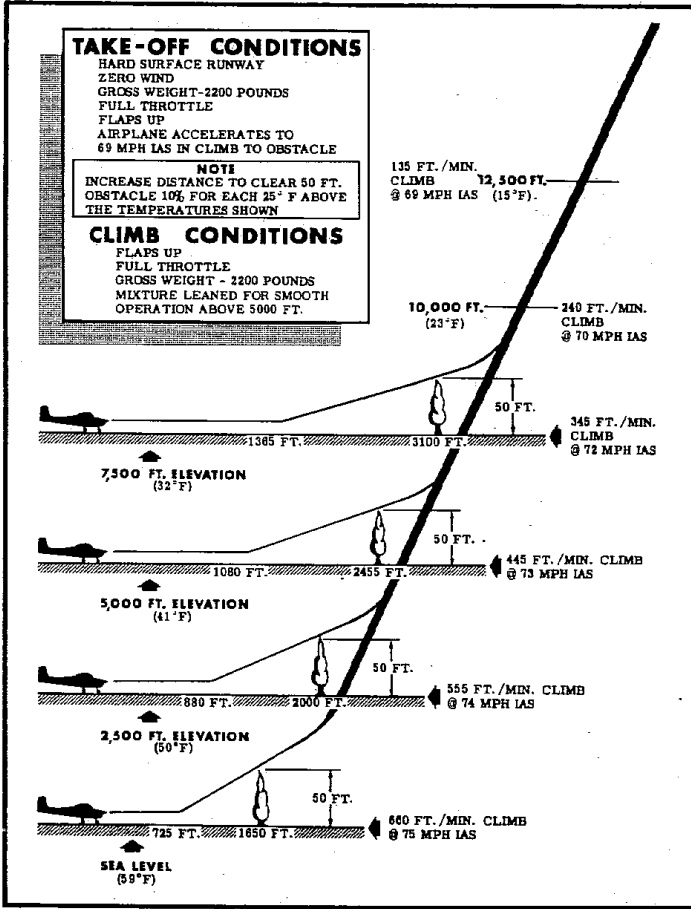

Figure 8. Take-Off Diagram

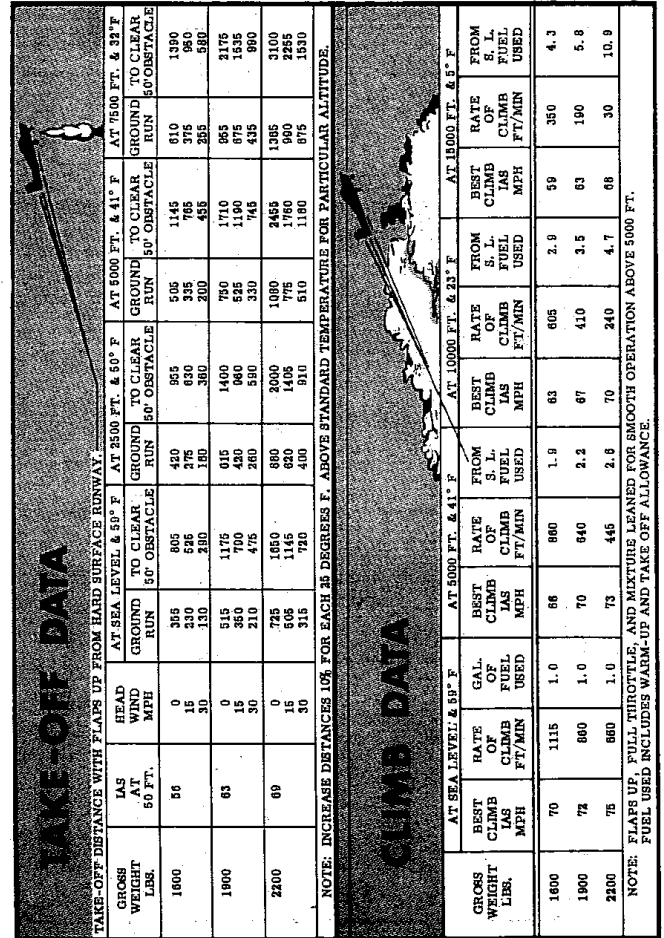

Figure 9. Take-Off & Climb Chart

CRUISE PERFORMANCE WITH RICH MIXTURE								
ALT	RPM	BHP	% BHP	TAS MPH	Gal./Hour	End Hours	Mi./Gal.	Range Miles
2,500	2100	66	45	84	7.2	5.1	13.1	484
	2200	74	51	102	7.8	4.7	13.0	482
	2300	83	57	108	8.5	4.4	12.8	474
	2400	92	64	114	9.2	4.0	12.4	458
	2500	103	71	120	10.1	3.7	11.9	440
	2600	116	80	126	11.2	3.3	11.3	417
2700	128	89	131	12.6	2.9	10.3	382	
5,000	2100	63	43	83	7.1	5.2	13.1	483
	2200	70	48	100	7.8	4.8	12.8	475
	2300	78	54	107	8.4	4.4	12.7	469
	2400	87	60	113	9.1	4.0	12.4	457
	2500	97	67	119	10.0	3.7	12.0	443
	2600	107	74	125	10.8	3.4	11.5	425
2700	120	83	131	12.1	3.1	10.8	401	
CRUISE PERFORMANCE WITH LEAN MIXTURE								
2,500	2100	66	45	94	5.7	6.5	16.5	610
	2200	74	51	102	6.5	5.7	15.7	580
	2300	83	57	108	7.3	5.1	14.9	552
	2400	92	64	114	8.1	4.6	14.1	521
	2500	103	71	120	9.0	4.1	13.3	491
	2600	116	80	126	10.1	3.6	12.4	458
2700	128	89	131	11.2	3.3	11.6	430	
5,000	2100	63	43	93	5.5	6.7	16.8	621
	2200	70	48	100	6.1	6.0	16.3	601
	2300	78	54	107	6.8	5.4	15.6	578
	2400	87	60	113	7.6	4.8	14.8	546
	2500	97	67	119	8.5	4.3	14.0	518
	2600	107	74	125	9.4	3.9	13.3	491
2700	120	83	131	10.5	3.5	12.4	460	
7,500	2100	60	42	89	5.3	7.0	16.9	626
	2200	66	46	97	5.8	6.4	16.7	620
	2300	73	51	105	6.4	5.8	16.4	607
	2400	82	56	111	7.2	5.2	15.5	575
	2500	91	63	118	8.0	4.6	14.8	548
	2600	101	70	124	8.9	4.2	14.0	519
10,000	2100	58	40	84	5.0	7.3	16.6	614
	2200	63	44	94	5.5	6.7	17.0	629
	2300	70	48	102	6.2	6.0	16.6	613
	2400	77	53	109	6.8	5.5	16.1	586
	2500	86	59	117	7.5	4.9	15.5	574
	2600	93	64	122	8.2	4.5	14.9	552
12,500	2200	61	42	90	5.3	6.9	16.8	623
	2300	66	46	98	5.8	6.4	16.9	626
	2400	74	51	107	6.5	5.7	16.6	612
	2500	80	55	114	7.0	5.2	16.2	597

Figure 10. Cruise Performance Chart

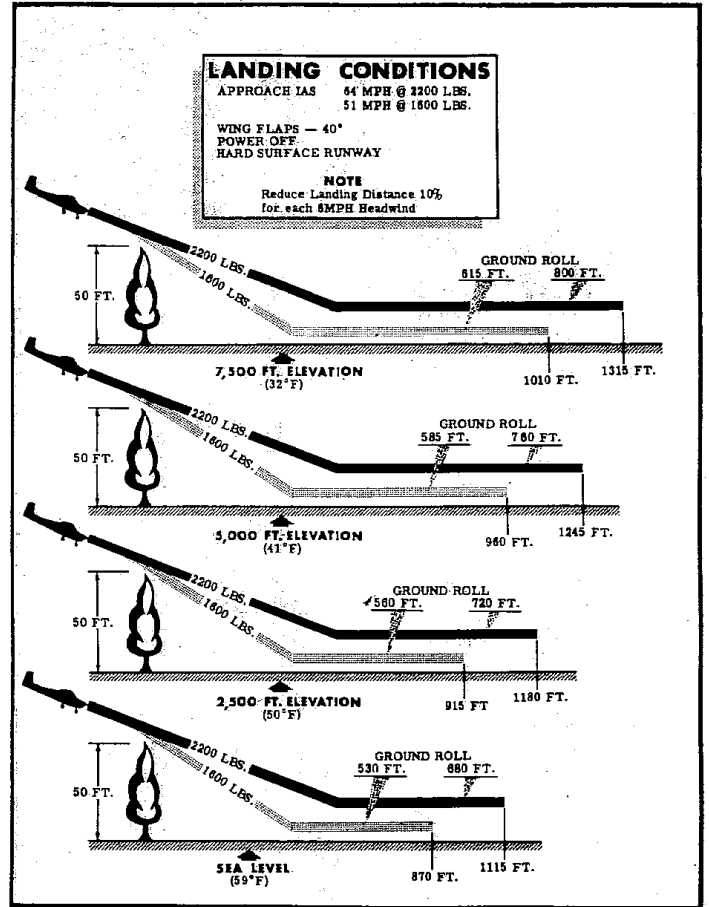

Figure 11. Landing Diagram

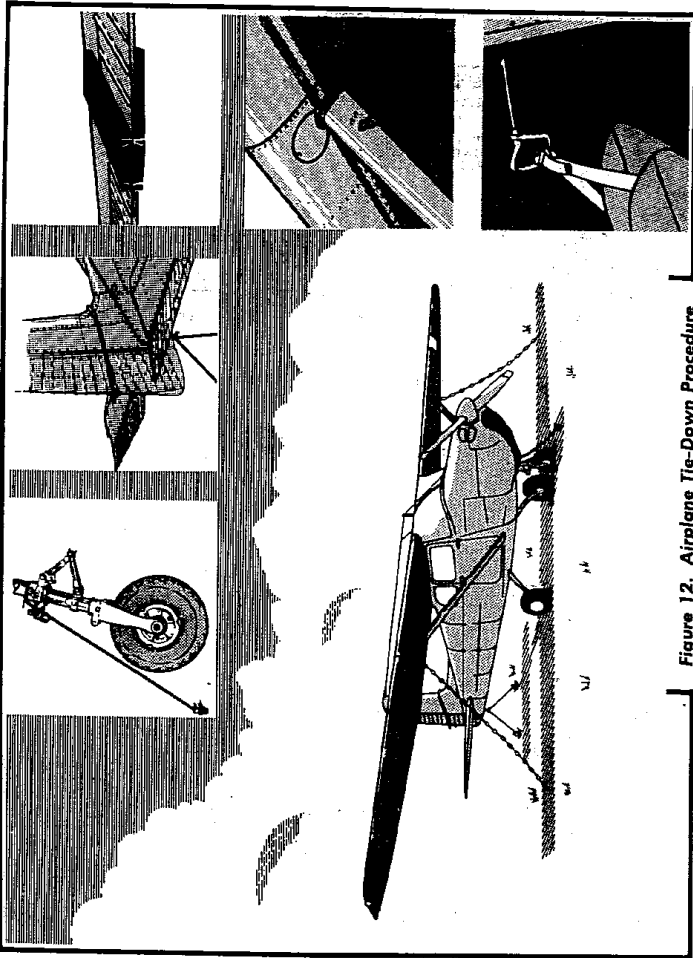

Figure 12. Airplane Tie-Down Procedure

## SECTION VI

### care of the airplane— owner's responsibilities

IF YOUR AIRPLANE is to retain that new plane performance, stamina, and dependability, certain requirements in its care, inspection, and maintenance must be followed. It is always wise to follow a *planned* schedule of lubrication and maintenance based on the climatic and flying conditions encountered in your locality.

Keep in touch with your Cessna dealer and take advantage of his knowledge and experience. He knows your airplane and how to maintain it. He will remind you when lubrications and oil changes are necessary and about other seasonal and periodic services.

#### GROUND HANDLING.

The airplane is most easily and safely maneuvered, during ground handling, by the use of a tow-bar attached to the nose wheel. Always use a tow-bar when one is available. When moving the airplane by hand and no tow-bar is available, push down at the front edge of the stabilizer adjacent to the fuselage to raise the nose wheel off the ground. When the nose wheel is held clear of the ground the airplane can be readily turned in any direction by pivoting it about the main gear. *Do not push down on the empennage by the tip of the elevator; likewise, do not shove sideways on the upper portion of the fin.* When moving the airplane forward or backwards, push at the wing strut root fitting or at the main gear strut.

#### MOORING YOUR AIRPLANE. (See figure 12.)

Proper tie-down procedure is your best precaution against damage to your parked airplane by gusty or

strong winds. To tie-down your airplane securely, proceed as follows:

- (1) Tie sufficiently strong (700 pounds tensile strength) ropes or chains to the wing tie-down fittings located at the upper end of each wing strut.
- (2) Secure the opposite ends of these ropes or chains to tie-down rings suitably anchored to the ground.
- (3) Tie a rope or chain thru the nose gear tie-down ring and secure the opposite end to a tie-down ring in the ground.
- (4) Securely tie the middle of a length of rope to ring at tail. Pull each end of rope away at 45° angle and secure to tie-down rings positioned on each side of tail.
- (5) Install surface control locks between the flap and aileron of each wing.
- (6) Tie left control wheel back with front seat belt.
- (7) Install surface control lock over fin and rudder.

**STORAGE.**

The all-metal construction of your Cessna makes outside storage of it practical. Inside storage of the plane will increase its life just as inside storage does for your car. If an airplane must remain inactive for a time, cleanliness is probably the most important consideration—whether your airplane is inside or outside. A small investment in cleanliness will repay you many times in not only keeping your airplane looking like new but in keeping it new. A later paragraph in this section covers the subject in greater detail.

Dirt and mud have the same effect as salt, only to a lesser degree—and do not neglect the engine when storing the airplane. Turn it over by hand or have it turned over every few days to keep the bearings, cylinder walls, and internal parts lubricated. Full fuel tanks will help prevent condensation and will increase fuel tank life.

Airplanes are built to be used and regular use tends to keep them in good condition. An airplane left standing idle for any great length of time is likely to deteriorate more rapidly than if it is flown regularly, and should be carefully checked over before being put back into service.

**LIFTING AND JACKING.**

The airplane may be lifted by an appropriate sling at the engine mount fuselage attachment fitting and a sling around the aft section of the fuselage. The upper half of the cowl must be removed for application of the sling

at the engine mount fuselage attachment fitting.

Jacking point brackets and hoisting rings are available as optional equipment and insure easy, safe handling of the airplane. A block of hardwood sawed at an angle to fit between the fuselage and the main landing gear spring may be used as a jacking point to hold the airplane when working on a main wheel or tire. Do not use the brake casting as a jacking point.

To remove the nose wheel, the airplane may be held in a nose high attitude by holding the tail down or by placing a padded support under the aft end of the nose gear support forging. Brake or block the main wheels when the nose wheel is being raised for removal.

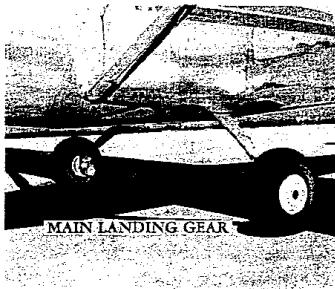
**LANDING GEAR, WHEELS, AND TIRES.**

The main landing gear consists of a single tapered spring leaf for each main gear. This spring is made from the highest quality chrome vanadium

steel, heat treated and shot peened for added fatigue resistance. No maintenance of this spring is necessary other than paint to prevent rusting.

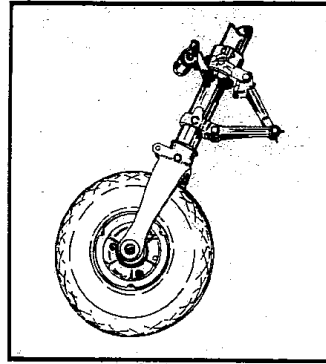

The steerable nose wheel is mounted on an air-oil shock strut which incorporates a shimmy dampener to assure smooth operation. This nose gear makes ground handling, taxiing, and landing both easier and smoother.

Correct tire pressure is essential to realize the full benefit of the landing gear and to obtain maximum tire wear. Correct tire pressure for the main gear is 24 lbs. per sq. inch gage pressure and for the nose gear it is 20 lbs. per sq. inch. An accumulation of oil and grease on tires will have an adverse effect on tire life and should be removed with soap and water.

Tires are easily removed by jacking up the airplane, removing the wheel, and disassembling the two piece wheel. Be sure that all of the air is out of the tire and tube before taking the wheel

apart. The tire is reinstalled by reversing the procedure. In removing the wheel, it is necessary to remove the brake disc anti-rattle clips before the wheel can be taken off the axle. The wheel axle nut should be tightened finger tight plus one-half turn.

The wheel alignment has been properly set at the factory. Excessive tire wear indicates an improper wheel setting for the "on the ground" weight at which you are operating. See your dealer for re-alignment.

The brake master cylinders, located in the cabin at the rudder and brake pedals, incorporate a reserve reservoir for brake fluid to replace leakage losses. The reservoir fluid level must be checked periodically, and the reservoir kept full at all times. The brake master cylinders should be serviced, as required, with MIL-O-5606\* a petroleum base hydraulic fluid. (Do not use castor oil base hydraulic fluid). Adjustment of the brake is not necessary. Whenever the brakes feel spongy, bleed out the entrapped air from the top of the actuating cylinder at the brake and refill the hydraulic reservoir at the pedals.

The nose gear air oil shock strut is filled as follows:

1. Remove valve cap and release all air.
2. Remove valve housing assembly.
3. Compress strut completely (stops in contact with outer barrel hub).
4. Oil level.
  - a. On Model 172 aircraft, fluid level should be maintained at 2 1/16 inches, ± 1/8 inches be-

\* Also MIL-H-5606

low the valve housing assembly mounting face. (This level may be checked with a dip-stick thru the valve housing assembly opening.)

- b. Fluid used should comply with specification MIL-O-5606.
- 5. Fully extend strut.
- 6. Replace valve housing assembly.
- 7. With strut fully extended and nose wheel clear of ground, inflate strut to 50 PSI.

The shimmy dampener fluid level should be checked at least every 25 hours. When filling the shimmy dampener, turn the nose wheel as far as it will go to the right. This eliminates the possibility of entrapping air behind the piston within the dampener assembly. Remove the cap from the reservoir and fill the reservoir with MIL-O-5606 hydraulic fluid. When disassembling the dampener for cleaning or repair it will be noticed that O-rings or wiper rings are never installed on the dampener piston even though provisions are made for such rings. When assembling the dampener, do not install an O-ring or a wiper ring on the piston.

**BATTERY.**

The battery is located under the cowling on the left side and is reached by raising the left cowl access door.

Maintain the level of the battery electrolyte at the level of the horizontal baffle plate (the plate with the holes in it) which is approximately two inches below the filler plug by adding distilled water as required. Obtain the

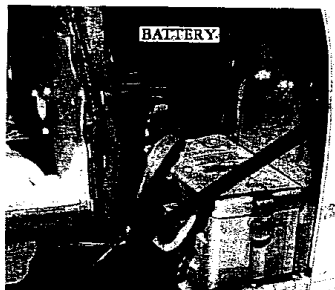

water level but *do not* fill above the plate mentioned above. This water level should be maintained when the battery is in the level position.

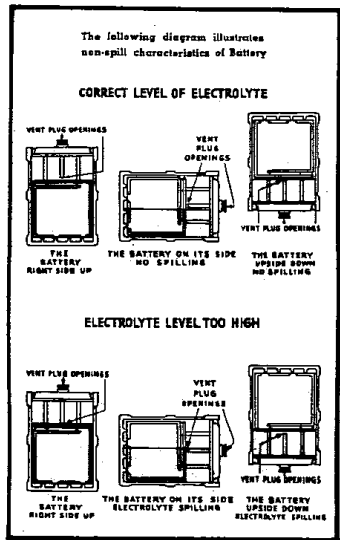

The space above the horizontal plate is a fluid reservoir when the battery is tipped to the side or inverted. When the electrolyte level is too high, spillage of fluid will result when acrobatic maneuvers are performed and as a result, the proper concentration of acid will be destroyed. Sponge off any spilled acid and corrosion products with soda water solution to neutralize acid, then rinse with clear water. Do not use excessive amounts of soda water.

Keep battery connections tight and clean, otherwise excessive voltage may be generated and damage other electrical equipment. Control of the charging current and voltage is accomplished by the generator regulator mounted on the firewall. *Only those persons familiar with the operation, adjustment, and repair of the control should be permitted to remove the cover of the device.*

The ammeter indicates the generator charging rate which will normally be in the neighborhood of 4 amps. Discharge generally indicates electrical energy drain in excess of generator output — resulting from:

- (1) Use of a large number of electrical units.
  - (2) Malfunctioning generator.
  - (3) A short in the electrical system.
- (2) and (3) require corrective measures. Failure of the ammeter to indicate will generally be a wiring problem or a malfunctioning indicator.

The airplane should not normally

be operated with the master switch in the "off" position nor should it be operated without a battery or with battery disconnected. Damage to the generator and the voltage regulator may be the result.

The master switch on the instrument panel operates a solenoid located at the battery. Occasionally when the battery is allowed to get sufficiently low, it will not have enough energy to actuate the solenoid when the master switch is turned on resulting in the generator being unable to charge the battery. In this case, the battery should be removed and recharged.

**THE PLEXIGLAS WINDSHIELD AND WINDOWS.**

The windshield is a single piece, full floating, "free blown" unit of "Long-life" plastic. To clean plexiglas, wash with plenty of soap and water, using the palm of the hand to feel and dislodge any caked dirt or mud. A soft cloth, sponge, or chamois may be used, but only as a means of carrying water to the plastic. Dry with a clean, damp chamois. Rubbing with a dry cloth builds up an electrostatic charge on the glass so that it attracts dust particles from the air. Wiping with a damp chamois will remove this charge as well as the dust and is therefore recommended.

Remove oil and grease by rubbing lightly with a cloth wet with kerosene. *Do not use* gasoline, alcohol, benzene, acetone, carbon tetrachloride, fire extinguisher, or de-icing fluid, lac-

quer thinner or glass window cleaning spray as they will soften the plastic and will cause crazing.

If after removing dirt and grease no great amount of scatching is visible, the plexiglas should be waxed with a good grade of commercial wax. These waxes will fill in minor scratches and help prevent further scratching. The wax should be applied in a thin even coat and brought to a high polish by rubbing lightly with a clean, dry, soft flannel cloth.

Do not use a canvas cover for protection of the windshield when the airplane is tied out, unless freezing rain or snow is expected, as it will cause the plexiglas to craze.

### ALUMINUM SURFACES.

The Alclad 24ST used in the construction of Cessna airplanes requires a minimum in care to keep the surface bright and polished, neat, and trim looking. The airplane may be washed with clear water to remove dirt and with gasoline, carbon tetrachloride or other non-alkaline grease solvents to remove oil, grease and paint. Household type detergent soap powders are effective cleaners, but should be used cautiously since some of them are strongly alkaline. Dulled aluminum surfaces may be cleaned effectively with Bon Ami. A cleaning solution consisting of about two quarts of alcohol, two quarts of water and a package of powdered Bon Ami will be found to be particularly effective in cleaning the airplane to retain the bright appearance.

50

### ENGINE COMPARTMENT.

The engine section should be kept free of an accumulation of oil, grease, and dirt to prevent a fire hazard. The bulkhead between the cabin and the engine section is aluminized iron and may be cleaned with recommended solvent cleaners for grease and oil.

### UPHOLSTERY.

Keeping the inside of your airplane clean is no more difficult than taking care of the rugs and furniture in your home. It is a good idea to occasionally take the dust out of the upholstery with a whisk broom and a vacuum cleaner.

If spots or stains get on the upholstery they should be removed as soon as convenient before they have a chance to soak and dry. Cleaning fluids having a carbon tetrachloride or a naphtha base are recommended. Soap or detergents and water are not recommended for use on the seats since this will remove some of the fire retardant with which the seats have been treated. When using recommended cleaners, the following method is suggested:

- (1) Carefully brush off and vacuum all loose particles of dirt.
- (2) Don't use too much fluid. The seat cushions are padded with "foam rubber," and since volatile cleaners attack rubber, these paddings may be destroyed if the material gets soaked with the cleaner.
- (3) Wet a small, clean cloth with the cleaning solution, wring out thoroughly. Then open cloth

and allow the fluid to evaporate a trifle.

- (4) Tap the spot lightly with the cloth, but don't rub it. This will pick up particles which are too imbedded to be removed by brushing. Repeat several times, using a clean part of the cloth each time.
- (5) Moisten another piece of clean cloth with cleaner and allow to evaporate until barely damp. Now rub the spot lightly, working from the outside in toward the center. (This, as you probably know, keeps the spot from spreading and is less likely to leave a ring.) If necessary, repeat several times.
- (6) Brush again, to remove any further particles which may have become loosened.

Spots or stains on the plastic headliner material and Royalite side panels are easily removed using a clean cloth slightly dampened with water. A few light strokes over the area usually removes all dirt. Persistent stains, requiring the use of cleaning fluid, may be removed as described in the preceding steps, 3 through 6.

### METAL PROPELLER.

Little maintenance is required to keep your McCauley Mer-L-Prop in air-worthy condition. The blades should be thoroughly inspected at least every 25 hours for dents, nicks and scratches. When small dents and nicks appear, they should be carefully

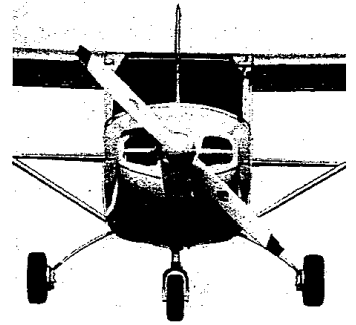

cut file, sandpaper and crocus cloth. An occasional wiping of the metal propeller with an oily cloth will result in cleaning off grass and bug stains and will assist materially in corrosion proofing in salt water areas.

### CONTROL SYSTEM.

Figures 13 to 19 incl. outline the control system including control travel limits, location of control stops, and the location of turnbuckles. The use of the single .040 brass wire for safetying of turnbuckles is satisfactory and CAA approved. Rigging method for the various systems is outlined below:

#### FLAPS:

1. Place the flap handle in the 0° flap position.
2. Hold the flap in the full-up position by applying firm hand

51

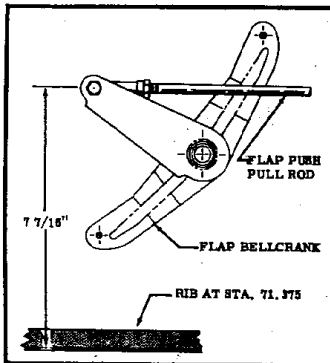

Figure 13. Flap Bellcrank Adjustment

pressure upward and forward against the trailing edge of the flap.

3. Adjust the flap push-pull rod until the flap bellcrank is in the position shown in figure 13.
4. Release the hand pressure that was applied to the flap trailing edge in step 2 and tighten the flap-up cable turnbuckle located under the cabin floor until cable has a tension of 20-40 pounds.
5. Repeat steps 2 thru 4 for the opposite flap.
6. Move flap handle to the flap full-down position.
7. Tighten the turnbuckles of the flap-down cables until the cables have a tension of 20 to 40 pounds.

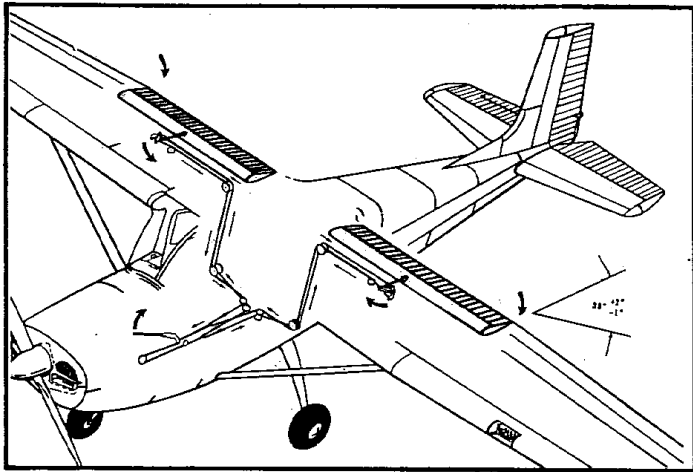

Figure 14. Flap Control System

**AILERONS:**

1. Place control wheels in neutral position and place a neutral bar across the top of both wheels, using tape or a clamp to secure them. Install chain over sprockets, leaving approximately nine links inboard of the chain guard on each side of the turnbuckle.
2. String cables back through system.
3. The ailerons on the Model 172 are restricted in travel by a feature built into the bellcranks. Stops in the bellcrank allow a total travel of 34°. In rigging the ailerons, it is important that the bellcranks are neutralized. Connect the cables and adjust bell-

crank to a position as shown in figure 16. Cable tension should be approximately 30 pounds with the control wheels in the full-forward position. This position should be maintained in checking the travel.

4. Adjust ailerons to neutral position, by reference to the wing flaps. This adjustment is made by disconnecting the aileron push-pull tube from the bellcrank, and making adjustment on the rod end at the aileron.
5. Check travel which should be 20° up and 14° down, with a tolerance of plus or minus 1°.
6. Any correction necessary on the travel can be made by tightening

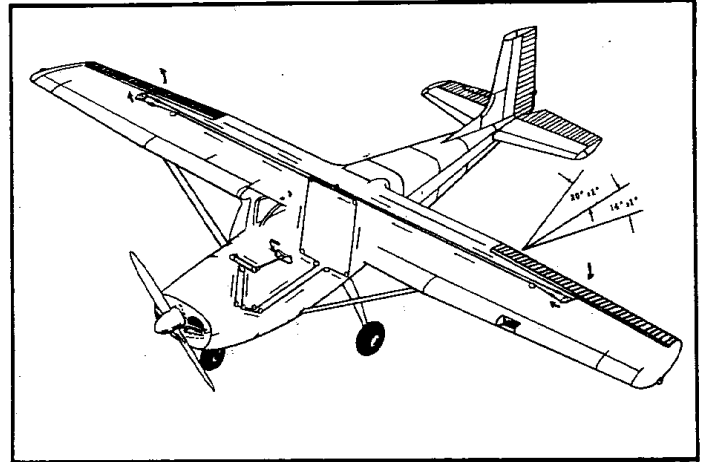

Figure 15. Aileron Control System

CARE — RESPONSIBILITIES

the direct cable and loosening the carry-through cable, or vice versa, whichever the case may be.

Note: After corrections have been made, check aileron in neutral position and make adjustment per instructions in Step 4.

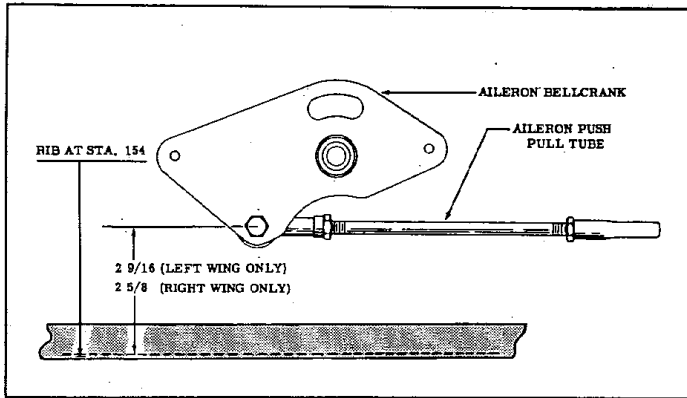

Figure 16. Aileron Bellcrank Adjustment

STEERING.

Nose wheel travel is 30° either side of neutral. Rig nose wheel as follows:

1. Rig rudder pedals so that in the neutral position they measure 6½" from the firewall to the hingeline of the brake pedals.
2. Attach the steering arms to the rudder bars with the nose wheel in the neutral position.
3. Adjust the steering arms until the steering rods are snug against the internal springs with the nose wheel in neutral position.

RUDDER.

Rudder travel is 16° from center-

line of the airplane, with a tolerance of plus or minus 1°. Travel is controlled by stops located on the extreme rear bulkhead. Adjustment is made by increasing or decreasing washer thickness under the head of the bolts which serve as stops.

1. Rig stops to allow correct travel of rudder.
2. Install cables, and with the rudder in neutral position, tighten turnbuckles until rudder pedals are neutral, 6½" aft of the firewall, measuring to the hingeline of the brake pedal.
3. Check to make sure cables do not rub side holes in bulkheads.

CARE — RESPONSIBILITIES

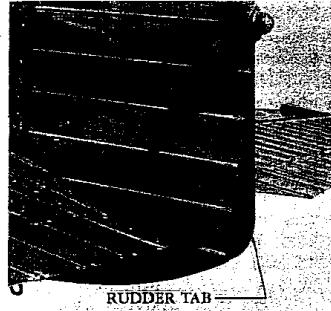

RUDDER TAB.

The rudder tab is a fixed tab located on the trailing edge of the rudder and

can be set by bending in either direction, the amount desired.

ELEVATORS.

Elevator travel is 28° + 1° - 0° up and 26° + 1° - 0° down. This travel is controlled by two stop bolts located in the stabilizer rear spar.

1. Set stop bolts so that elevator has correct travel when the aft elevator bellcrank is in contact with them.
2. With elevator in full down position, the measurement from firewall to the edge of the chain sprocket hub on the control column should be ½".
3. Tighten cables to approximately 30 lbs.

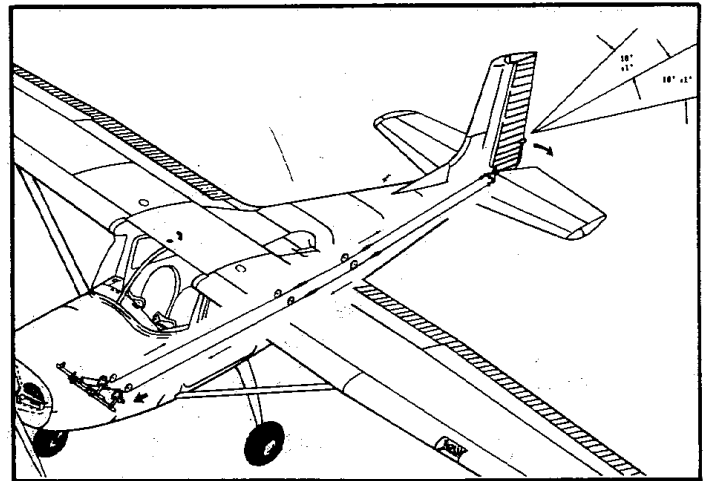
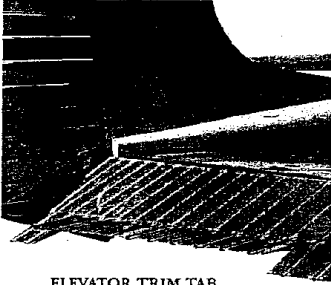

Figure 17. Rudder Control System



ELEVATOR TRIM TAB

**ELEVATOR TAB.**

The elevator tab is actuated by a cable which has a chain incorporated

in each end. The chain in front is actuated by the fingertip tab control, and the one at the rear operates a screwjack, which is mounted in the right half of the stabilizer. The travel is 28° up and 13° down, plus 1° or minus 0°.

1. Install cables. Turn tab control wheel to full-forward position, and screwjack to full up position. Then turn screwjack back ½ turn. Set the chain on sprockets at each end, allowing ½" to 1" overlap in direction of travel. Tighten cable tension to approximately 30 lbs.
2. To set tab travel, elevator *MUST BE* in neutral position.
3. Turn tab control to full-forward

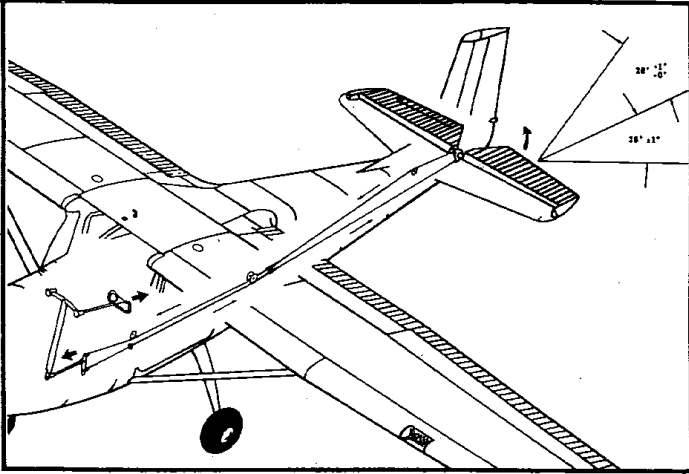

Figure 18. Elevator Control System



position, disconnect push-pull tube from tab and adjust it to hold the tab approximately 29°. (This can be done by screwing it in or out, whichever the case may be.) Connect the push-pull tube to the tab and turn the tab control to the full rearward position. The tab should be approximately 14°.

4. Set stops between first and second bulkheads rear of the baggage compartment on the cables for correct travel, which is 28° up and 13° down.

each rear spar attachment at neutral position. These two eccentric bushings should always be rotated together whenever the setting is changed. Never rotate them separately. If flight test shows excessive wing heaviness, re-rig by rotating the proper bushings, which will increase or decrease the angle of attack of the wing.

**WING ADJUSTMENT.**

Initial rigging is accomplished by setting the two eccentric bushings on

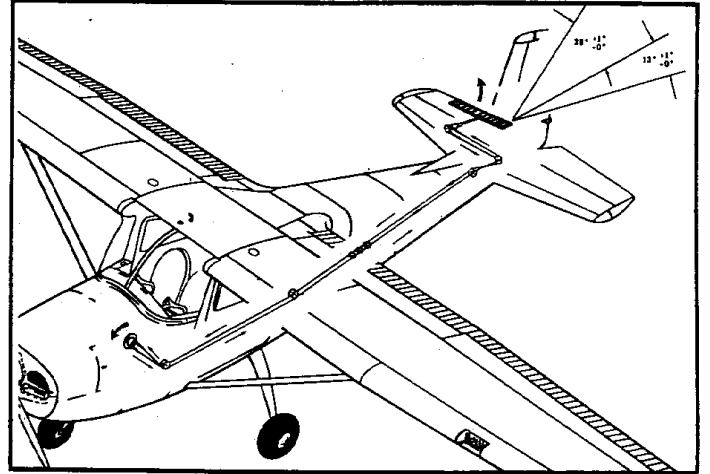

Figure 19. Elevator Tab Control System

## LUBRICATION.

Figure 20 outlines the lubrication requirements for the Cessna Model 172.

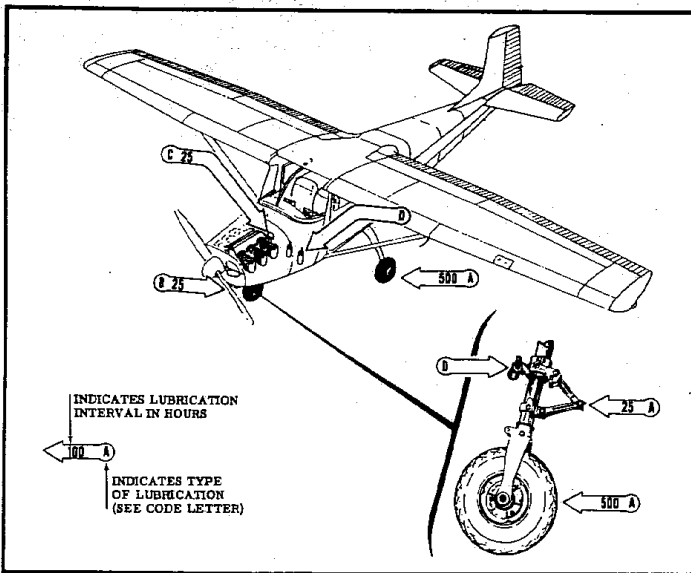

Figure 20. Lubrication Diagram

## Code Letter

## LUBRICATION CODE

- A—MIL-L-7711—Grease  
 B—Carburetor Air Filter—Wash in gasoline, coat both sides with (SAE 10) motor oil and allow to drain before re-installing. Service every 25 hours or oftener when operating in dusty conditions.  
 C—Engine Oil Tank—Check dip-stick before each flight. Drain and refill every 25 hours.  
 D—Brake Master Cylinders—Should be checked and refilled periodically with MIL-O-5606 Oil—Hydraulic (Petroleum base). Also shimmy dampener on nose wheel strut.

NOTE 1. All pulleys, trim tab actuator rod, control surface hinge bearings, bellcrank clevis bolts, flap actuating handle, brake pedal pivots,

rudder pedal crossbars, shimmy dampener pivot bushing, door hinge and mechanism, Bowden controls, throttle, control rod universal (if unsealed) and control column ball, should be lubricated with SAE 20 General Purpose light machine oil as required or every 1,000 hours.

NOTE 2. In general, roller chain (Aileron, Tab wheel, tab actuator) and control cable tend to collect dust, sand, and grit when greased or oiled. More satisfactory operation except under seacoast conditions results when the chains are wiped clean occasionally with a clean dry cloth.

## AIRPLANE FILE.

There are miscellaneous data, information and licenses that are a part of the airplane file. The following is a check list for that file:

- A. To be carried in the airplane at all times:
- (1) Aircraft Registration Certificate (Form ACA 500A).
  - (2) Aircraft Airworthiness Certificate (CAA Form ACA 1362).
  - (3) Airplane Radio Station License (if transmitter installed).
  - (4) Airplane Log Book.
  - (5) Engine Log Book.

- B. To be maintained but not necessarily carried in the airplane at all times:

- (1) Weight and Balance report or latest copy of the Repair and Alteration Form 337.
- (2) Equipment List.
- (3) A form containing the following information:  
 Model, Registration Number, Factory Serial Number, Engine Number and Key

Numbers (duplicate keys are available through your Cessna dealer).

## INSPECTION SERVICE AND INSPECTION PERIODS.

With your airplane you will receive an Owner's Service Policy. This policy has coupons attached to it which entitle you to a no-charge initial inspection and a no-charge 100 hour inspection. If you take delivery from your Dealer, he will perform the initial inspection before delivery of the airplane to you. If you pick up the airplane at the factory, plan to take your Cessna 172 to your Dealer reasonably soon after you take delivery on it. This will permit him to check it over and to make any other minor adjustments that may appear necessary. Also plan an inspection by your Dealer at 100 hours or 90 days whichever comes first. This inspection also is performed by your Dealer for you at no charge. While these important inspections will be performed for you by any Cessna Dealer, in most cases you will prefer to have the Dealer from whom you purchase the airplane accomplish this work for you.

The Civil Air Regulations require all airplanes to have an "annual inspection" as prescribed by the administrator, by a person designated by the administrator, and in addition, 100 hour periodic inspections made by an "appropriately rated mechanic" if the airplane is flown for hire. The Cessna Aircraft Company recommends the 100 hour periodic inspection for the Model 172 airplanes. The procedure for this 100 hour inspection has been carefully worked out by the factory and is followed by the Cessna dealer organization. The complete familiarity of the Cessna dealer organization with Cessna equipment and with Cessna procedures provides the highest type of service possible at lower cost.

Time studies of the 100 hour inspection at the factory and in the field have developed a standard flat rate charge for this inspection at any Cessna Dealer. Points which the inspection reveals require modification or repairs will be brought to the owner's attention by the dealer and quotations or charges will be made accordingly.

#### 100 HOUR INSPECTION.

Before beginning the inspection, shop foreman or mechanic runs the engine to check for magneto drop, generator charge and general smoothness of operation of the engine and records these facts as an aid to the mechanic. The inspection consists basically of the following procedure:

- I. Remove all inspection plates and necessary fairing consisting of the following:
  1. Remove front strut inspection plates (both sides).
  2. Remove lower half of wing root fairing (both sides).
  3. Remove two round inspection plates at aileron bellcrank.
  4. Remove two flap pulley inspection covers on top of the wing-root-to-cabin-junction-section forward of the flap.

The inspection charge does not include the oil required for the oil change.

Every effort is made to attract the best mechanics in each community to Cessna service facilities. Many dealers' mechanics have attended Cessna Aircraft Company schools and have received specialized instruction in maintenance and care of Cessna airplanes. Cessna service instruction activity in the form of service bulletins and letters is constantly being carried on so that your enjoyment and safety in your Cessna will be complete and up-to-date when you have your inspection and service work performed by Cessna dealers' mechanics.

Cessna dealers maintain stocks of genuine Cessna parts and Service facilities consistent with the demand.

Your Cessna dealer will be glad to give you current price quotations on all parts that you might need and will be glad to advise you on the practicability of parts replacement versus repairs that might from time to time be necessary.

5. Remove round inspection plate from the tail cone just to the right of the dorsal fin.
6. Remove tail group fairing and round plate on left side under the fin.
7. Remove round plate on underneath right side of the stabilizer.
8. Remove engine cowl.
9. Remove the two round inspection plates on the under side of the cabin section outside skins.
10. Open the upholstery zipper above the rear seat.
11. Remove the two round plates on the top side of the landing gear bulkhead.
12. Remove rear center tunnel covers between the front seats.
13. Open curtains at the aft end of the baggage compartment for access to the cables, bellcranks and pulleys. It is necessary to crawl back into the fuselage for proper inspection.
14. Open landing gear fairing.

#### II. Engine Check.

1. Remove heater mufflers. Inspect mufflers and exhaust stacks for possible cracks.
2. Check carburetor air and heater hoses for holes, collapsed tubes, burning, and security of mounting.
3. Drain oil and clean oil strainer located on rear side of accessory case and replace oil.
4. Check magneto, touching up points if necessary, and check timing. Right Magneto 26° B.T.C., Left Magneto 28° B.T.C.
5. Check cylinder base nuts for tightness.
6. Check for oil leaks. *015-018'*
7. Remove spark plugs, clean if necessary, check gap spacing and replace.
8. Wash down engine.
9. Check engine mount bolts for security.
10. Check all wires forward of the firewall.
11. Check all engine controls for travel and free movement.
12. Remove and clean gasculator bowl and screen.
13. Check propeller track and inspect for bad nicks or cracks.
14. Check starter travel.
15. Clean carburetor air screen, re-oil and reinstall.
16. Check battery water level.
17. Replace engine cowling.

#### III. Wing Inspection.

1. Check front and rear wing bolts attaching wing to fuselage (both wings).
2. Check out strut bolts for security (both wings).

#### CARE — RESPONSIBILITIES

3. Check all wing control surfaces for freedom of movement and bolts for security.
4. Check aileron bellcranks (both sides).
5. Check flap bellcranks, tracks, and pulleys (both sides).
6. Drain wing fuel tank sumps.

#### IV. Empennage and Surfaces.

1. Check both stabilizer, and vertical fin, for possible damage.
2. Check attaching bolts on both fin and stabilizer for security.
3. Check rudder and elevator attaching bolts for security and surfaces for freedom of movement.
4. Check elevator and rudder hinge connections for cracks.
5. Check surface travels. Elevator  $28 \pm 1^\circ$  —  $0^\circ$  up and  $26 \pm 1^\circ$  down. Elevator tab  $28 \pm 1^\circ$  up and  $13 \pm 1^\circ$  down, Rudder travel  $16^\circ$  right  $16^\circ$  left, Aileron  $20^\circ$  up  $14^\circ$  down, and Flaps  $38^\circ + 2^\circ - 1^\circ$  down.
6. Check elevator bellcrank and rudder bellcrank.
7. Clean nose gear assembly. Check for security and freedom of operation. Grease lube fittings. Pack wheel at 500 hours. Check nylon on center position lock for wear. Check steering arms for security. Check inflation of strut. Fill shimmy dampener.
8. Check rigging of steering. With rudder pedals in neutral, they should measure  $6\frac{1}{2}''$  from firewall to the hingeline of the brake pedal. With rudder pedals neutral, nose wheel should be in neutral position with no slack in steering rods.

#### V. Cabin Section.

1. Clean cabin section, vacuum it if possible.
2. Inspect rudder bar and brake assembly and the control tee for the security of mounting. Inspect cable connection points. Check pulley installations.
3. Suspend landing gear wheels from floor and remove outer wheel fairings. Shake landing gear and wheels for any sign of looseness and visually inspect fuselage attachment. If necessary tighten landing gear bolts. With airplane in level position on the floor visually inspect landing gear spring leaf underside for cracks. (Remove landing gear wheels and pack with grease every 500 hours unless otherwise designated by owner.)
4. Drain sediment and water from fuel line at plug located on the belly of the airplane.

#### VI. Electrical System.

1. Check electrical system by operating the lights, starter, and all accessories which are incorporated in the electrical system.

#### VII. Recowl the engine. Replace all inspection plates and fairings.

#### CARE — RESPONSIBILITIES

#### VIII. Run engine.

1. Check magnetos for drop.
2. Check generator for proper charge.

### Cross Country Service

On your cross country travels, make it a point to stop at a Cessna service station for your service requirements. Your Dealer will be glad to supply you with a copy of a current service station list, or if you wish, you may write to the Service Department, Cessna Aircraft Company, Wichita, Kansas, asking for it and it will be promptly mailed to you.

**ELECTRICAL SYSTEM.**

Figure 21 outlines the 12-volt electrical system including electrical accesso-

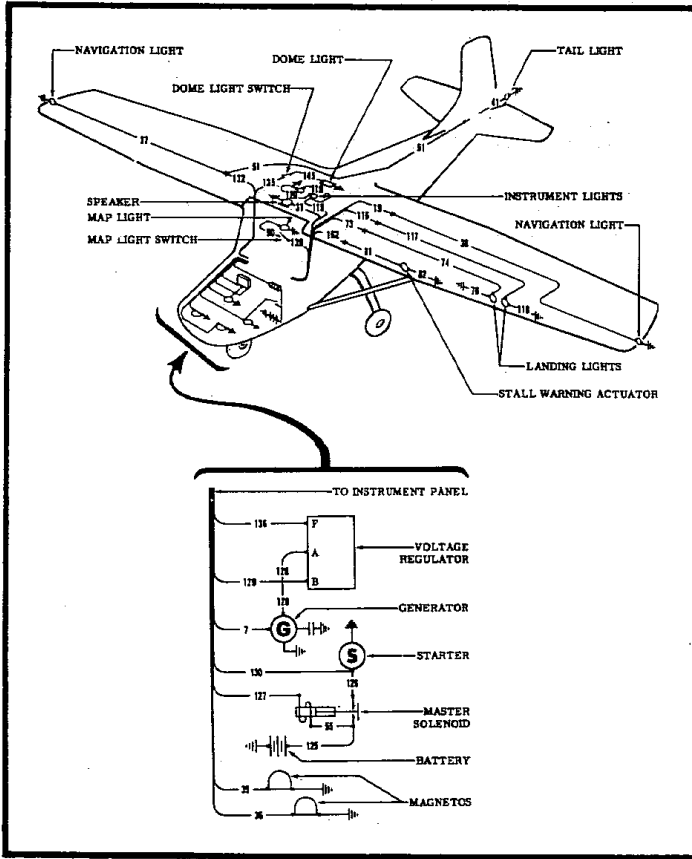
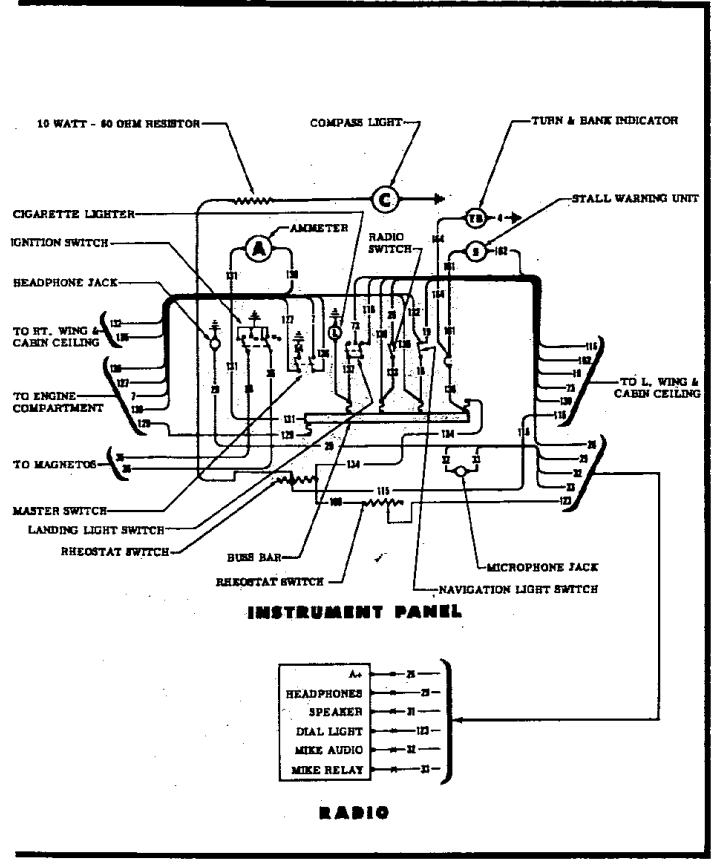
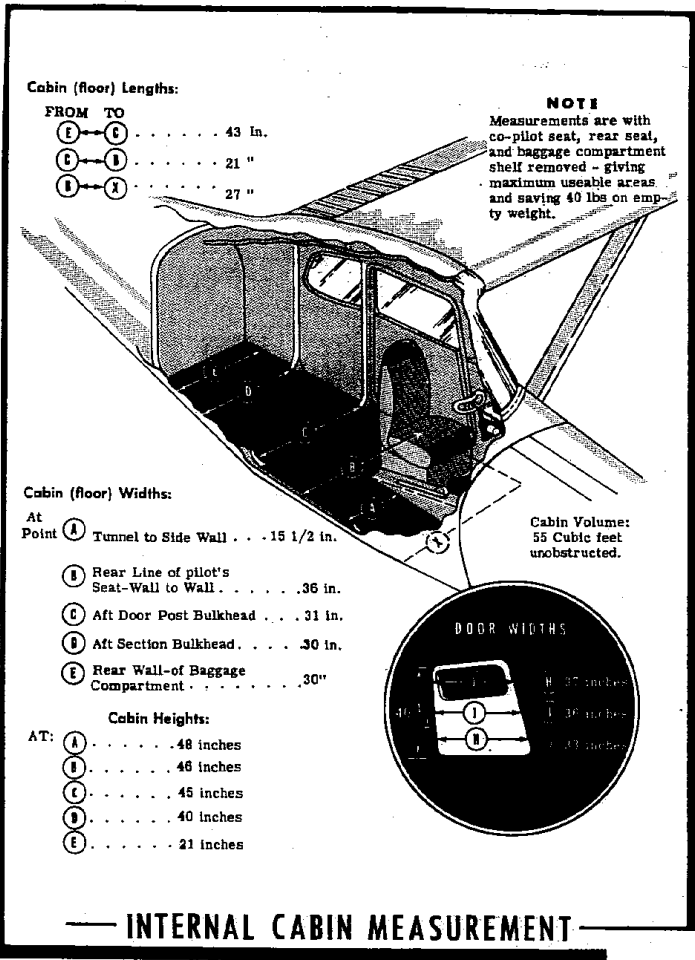

Figure 21. Electrical

ries. The numbers indicate wire numbers which can be found on each wire in the airplane.



Wiring Diagram



# Optional

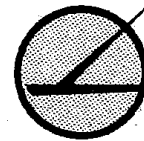

# Equipment

## RADIO EQUIPMENT

See your Cessna sales and service dealers for the complete line of radio combinations available for your Cessna.

## INSTRUMENT EQUIPMENT

- Turn and Bank Indicator
- Rate of Climb Indicator
- Sensitive Altimeter
- Clock
- Gyro Horizon
- Directional Gyro
- Manifold Pressure Gage
- Carburetor Temperature Gage (Electric)
- Outside Air Temperature Gage
- Cylinder Head Temperature Gage
- Venturi System
- Safe Flight Speed Control System

## WINTERIZATION EQUIPMENT

- Winterization Kit
- Oil Dilution System

## MISCELLANEOUS ACCESSORIES AND EQUIPMENT

- L-2 Lear Auto Pilot
- Low Frequency Antenna and Mast
- Dual Controls
- Landing Light
- Corrosion Proofing
- Jack Points
- Shoulder Straps
- Fire Extinguisher (1 Quart Hand Type)
- Sun Visors
- Cargo Tie Down Lugs
- Navigation Light Flasher
- Stabilizer Abrasion Boots
- Heavy Duty Axles
- Flares (3 1/2 Minute Flares)
- Oil Filter
- Ground Service Plug
- Seat Covers
- Stretcher Installation
- Tow Bar

## ALPHABETICAL INDEX

### A

After Landing, 27  
 Aileron Control System, 53  
 Airspeed Indicator, 14  
 Airspeed Limitations, 35  
 Alignment, Wheel, 46  
 Altimeter, 14, 67  
 Aluminum Surfaces, 50  
 Ammeter, 10  
 Ash Receivers, 20  
 Assist Handle, 19  
 Assist Steps, 20  
 Assist Strap, 20

### B

Baggage Compartment, 21  
 Bank and Turn Indicator, 14, 67  
 Battery, 48  
 Before Entering Airplane, 23  
 Before Landing, 26  
 Before Starting Engine, 23  
 Before Take-Off, 24  
 Brake Control, Parking, 14  
 Brake Fluid, 47  
 Brake Pedals, 14  
 Brake System, 12  
 controls, 14

### C

Cabin Door, 18  
 Cabin Heater, 17  
 manifold, 17  
 Cabin Ventilators, 16  
 Cabin Windows, 19  
 Carburetor Air Heat Control, 2  
 Carburetor Air Temperature Gage, 67  
 Cargo Tie-down Lugs, 68  
 Cigarette Lighter, 20  
 Check List, 23  
 Cleaning  
 aluminum surfaces, 50

### D

Directional Gyro, 67  
 Dome Light, 16  
 Door, Cabin, 18  
 Door Handle, 18  
 Door Lock, 18  
 Drain Plugs  
 fuel tank sump, 7  
 fuel line, 7  
 Drain Valve, Fuel Strainer, 7

battery, 48  
 engine compartment, 50  
 metal propeller, 51  
 tires, 47  
 windows, 49  
 windshield, 49  
 upholstery, 50  
 Clearing the Propeller, 29  
 Climb, 26, 31  
 Clock, 15  
 Coat Hanger Hook, 21  
 Cold Weather Operation, 33  
 Compartment, Baggage, 21  
 Compass, Magnetic, 15  
 Control  
 aileron, 10, 53  
 cabin heater, 17  
 carburetor air heat, 2  
 elevator, 10, 55  
 elevator tab, 11, 56  
 flap, 11, 51  
 flight, 10, 51  
 mixture, 1  
 parking brake, 14  
 rudder, 11, 54  
 throttle, 1  
 wheels, 10  
 Controls, Engine, 1  
 Control System, 10, 51  
 Cross Country Service, 63  
 Cruise Performance, 42  
 Cruising, 26, 29, 31

**E**

Electrical System, 8, 64, 65  
 controls, 8  
 indicators, 10  
 wiring diagram, 9, 64, 65  
 Elevator Control System, 55  
 Elevator Tab Control System, 56  
 Elevator Tab Control Wheel, 11  
 Engine, 1  
 before starting, 23  
 compartment, 50  
 controls, 1  
 cruising, 29  
 idling, 30  
 indicators, 3  
 let-down, 30  
 operating limitations, 36  
 operating procedure, 29  
 primer, 3  
 starting, 23, 29  
 stopping, 30  
 take-off, 29  
 warm-up, 29  
 Extinguisher, Hand-Operated Fire, 68

**F**

Filler Cap, Oil, 5  
 File, Airplane, 59  
 Fire Extinguisher, Hand-Operated, 68  
 Flap Control System, 51  
 Flap Handle, Wing, 11  
 Flares, 68  
 Flight Control System, 10, 51  
 controls, 10  
 Flight Restrictions, 35, 36  
 Front Seal, 18  
 Fuel Line Drain Plug, 7  
 Fuel Quantity Indicator, 7  
 Fuel Selector Valve, 5  
 Fuel Strainer Drain Valve, 7  
 Fuel Specification and Grade, 5  
 Fuel System  
 controls, 5  
 indicator, 7  
 Fuel Tanks, 5  
 Fuel Tank Sump Drain Plugs, 7  
 Fuses, 10

**G**

Gage  
 carburetor air temperature, 67

oil pressure, 5  
 outside air temperature, 67  
 Ground Handling, 45  
 Gyro, Directional, 67

**H**

Hand-Operated Fire Extinguisher, 68  
 Handle, Assist, 19  
 Handle, Door, 18  
 Heating System, 17  
 controls, 17  
 operation, 17  
 Hook, Coat Hanger, 21

**I**

Idling, Engine, 30  
 Ignition Switch, 3  
 Indicator  
 airspeed, 14  
 fuel quantity, 7  
 oil temperature, 5  
 turn and bank, 14, 67  
 stall warning, 14  
 vertical speed, 67  
 Inspection Service and Inspection Periods, 59  
 Instruments, 14  
 Instrument Markings, 35, 36  
 Instrument Lights, 15  
 Internal Cabin Measurement, 66

**J**

Jacking and Lifting, 46

**K**

Key Lock, 19  
 Knob  
 cabin heater control, 17  
 carburetor air heat control, 2  
 mixture control, 1  
 starter, 3

**L**

Landing, 27, 32  
 crosswind, 27  
 normal, 27  
 short field, 27  
 Landing Gear, 12, 46  
 Landing Light Switch, 15  
 Landplane  
 landing, 27, 32  
 take-off, 25  
 taxiing, 30  
 Latch, Thumb, 19  
 Latch, Window, 19  
 Let-down, 26, 30  
 Lifting and Jacking, 46  
 Lights  
 dome, 16  
 instrument, 15  
 landing, 15  
 map, 16  
 navigation, 15  
 radio dial, 16  
 Lighting Equipment, 15  
 Lighter, Cigarette, 20  
 List, Check, 23  
 Loading Your Cessna 172, 21  
 Lock, Key, 19  
 Lubrication, 58  
 diagram, 58

**M**

Magnetic Compass, 15  
 Manifold Cabin Heater, 17  
 Maneuvers  
 normal category, 35  
 Map Pockets, 21  
 Master Switch, 8  
 McCauley Propeller, 51  
 Mixture Control, 1  
 Mooring Your Airplane, 45

**N**

Navigation Lights, 15  
 switch, 15  
 Navigation Light Flasher, 68  
 Night Flying, 35  
 Nose Gear, 12

**O**

Oil Dilution System, 68  
 Oil Filler Cap, 5  
 Oil Filter, 68  
 Oil Level, 3  
 Optional Equipment, 67, 68  
 Oil Pressure Gage, 5  
 Oil Specification and Grade, 5  
 Oil System, 3  
 indicators, 5  
 Oil Temperature Indicator, 5  
 Operational Data, 39  
 Operations Authorized, 35  
 Operating Check List, 23  
 Operating Limitations, 35  
 Outside Air Temperature Gage, 67

**P**

Parking Brake Control, 14  
 Parking Brake, Operation, 14  
 Pedals, Brake, 14  
 Pedals, Rudder, 11  
 Permissible Acrobatics, 35  
 Pitot-Static System Indicators, 14  
 Pitot Tube, 14  
 Pockets, Map, 21  
 Port, Static, 14  
 Pressure Tire, 47  
 Primer, Engine, 3  
 Propeller Metal, 51

**R**

Radio Equipment, 67  
 Rate-Of-Climb Indicator, 67  
 Rear Seat, 18  
 Restrictions, Flight, 35, 36  
 Rheostat, Instrument Lights, 15  
 Rudder Control System, 54  
 Rudder Pedals, 11  
 Rudder Tab, 55

**S**

Seat Covers, 68  
 Seats, 18  
 front, 18  
 rear, 18

**S**

Sensitive Altimeter, 67  
 Settings, Wing Flaps, 12  
 Shelf, Utility, 21  
 Shoulder Straps, 68  
 Spins, 35  
 Stabilizer Abrasion Boots, 68  
 Stall Warning Indicator, 14  
 Stalling Speeds, 32  
 Stalls, 32  
 Starter Knob, 3  
 Starting Engine, 23  
 Static Port, 14  
 Steps, Assist, 20  
 Steering, 54  
 Stopping Engine, 30  
 Storage, Airplane, 46  
 Stretcher Installation, 68  
 Sun Visors, 68  
 Strap, Assist, 20  
 Switch  
   dome light, 16  
   ignition, 3  
   instrument lights, 15  
   landing light, 15  
   master, 8  
   navigation light, 15

**T**

Tachometer, 3  
 Take-Off, 25, 29, 31  
   crosswind, 25  
   minimum run, 25  
   normal, 25  
   obstacle clearance, 25  
   soft or rough field, 25  
 Tank, Fuel, 5  
 Taxiing Instructions, 30  
 Throttle, 1  
 Thumb Latch, 19

Tie-Down Lugs, Cargo, 68  
 Tie-Down Procedure, 44, 45  
 Tires, 46  
   pressure, 47  
 Turn and Bank Indicator, 14, 67

**U**

Upholstery, 50  
 Utility Shelf, 21

**V**

Valve, Fuel Strainer Drain, 7  
 Valve, Fuel Selector, 5  
 Ventilators, Cabin, 16  
 Venturi System, 67  
 Vertical Speed Indicator, 67

**W**

Warm-up, 29  
 Warm-up and Ground Test, 24  
 Weight and Balance, 36  
 Wheel Alignment, 46  
 Wheel, Control, 10  
 Wheel, Elevator Tab Control, 11  
 Wheel, Landing Gear, 46  
 Wheel, Nose, 12, 47  
 Window Latch, 19  
 Windows, Cabin, 19  
 Windshield, 49  
 Wing Adjustment, 57  
 Wing Flap Handle, 11  
 Winterization Equipment, 68  
 Wiring Diagram, 9, 64, 65

GLIDE RATIO = 11,2 : 1 at 80 MPH (IAS)

CLIMB 443 FT/Min @ 75 MPH IAS (STD T°) ± 1985 lbs G.W.

**WARRANTY**

■ The Cessna Aircraft Company warrants each new airplane manufactured to be free from defects in material and workmanship under normal use and service, provided, however, that this warranty is limited to making good at the Cessna Aircraft Company's factory any part or parts thereof which shall, within ninety (90) days after delivery of such airplane to the purchaser, be returned to the Company with transportation charges prepaid, and which upon Company examination shall disclose to the Company satisfaction to have been thus defective; this warranty being expressly in lieu of all other warranties expressed or implied and all other obligations or liabilities on the part of the Company, and the Company neither assumes nor authorizes any other person to assume for it any other liability in connection with the sale of its airplanes.

■ This warranty shall not apply to any airplane which shall have been repaired or altered outside the Company's factory in any way so as, in its judgment, to affect its stability or reliability, nor which has been subject to misuse, negligence or accident.